

Instruction Manual and Maintenance & Inspection Procedures

Automatic Tool Changer NITTAOMEGA XC60

NOTICE

For use of this document:

Please keep this document always readily available to those who use the product. If you need an additional copy, please download the document from our website:

<https://www.nitta.co.jp/en>

Nitta Corporation

Osaka HQ: 4-4-26 Sakuragawa, Naniwa-ku, Osaka, Osaka 556-0022

Tel: +81 6-6563-1271

FAX: +81 6-6563-1272

Tokyo Branch: 8-2-1 Ginza, Chuo-Ku, Tokyo 104-0061

Tel: +81-3-6744-2725

FAX: +81-3-6744-2707

Nagoya Branch: 1-17-23 Meieki-Minami, Nakamura-ku, Nagoya 450-0003

Tel: +81-52-589-1321

FAX: +81-52-566-2005

Nabari Plant: 1300-45 Yabata, Nabari, Mie 518-0494

Tel: +81-595-64-2916

FAX: +81 595-63-9527

Issued: September 2013

Revised: December 2018

Ver. No.: rev3

Contents

Preface	I
Notice	I
Product Warranty	I
Unpacking and Check	I
Safety Precautions	II
1. Overview of the Automatic Tool Changer (ATC)	1
1-1. Robot Side	1
1-1-1. Robot Adaptor	1
1-1-2. Robot Adaptor plate	2
1-2. Tool Side	2
1-2-1. Tool Adaptor	2
1-2-2. Tool Adaptor Plate	2
1-3. Options	2
2. Composition	3
3. Standard Specifications	4
3-1. ATC Specifications	4
3-2. Chuck/Unchuck Sensor Specifications	5
3-2-1. Coupling Check End Sensor	5
3-2-2. Lead Switch for Chuck and Unchuck	5
3-3. Fall Protection System Specifications	6
3-4. Precautions for Allowable Load and Installation	7
3-5. Allowable Electric Load	7
4. Part Names	8
5. Procedures of Installation to Robot/Tool	9
5-1. Robot Adaptor	9
5-2. Tool Adaptor	9
5-3. Connecting to Chuck/Unchuck Port	11
5-4. Electric Wiring	12
5-5. User Air Piping (Standard)	13
5-6. Cable Fixing	13
5-7. Precautions for Installing ATC to a Tool, etc.	14
5-7-1. ATC Orientation	14
5-7-2. Proximity of ATC	14
6. Operations and Programming	15
6-1. Checking before Teaching (Robot Operations)	15
6-2. Operations and Programming	16
6-3. Basic ATC Flow	17
6-4. Interlocking around ATC	18
6-5. Precautions for Operations	19
6-6. Points to Check during Line Downtime (or Line Uptime)	20
6-7. Emergency Response Actions	21
6-7-1. Manual Unchuck in Case of Emergency	21
6-7-2. Response Actions to Interference or Crash	22
6-7-3. Response Action to Water Exposure	22
6-8. Precautions for Using a Servo Motor for a Tool	23
6-9. Precautions for Transportation	23
7. Maintenance and inspection	24
7-1. Maintenance and Inspection Schedule	24
7-2. Maintenance and Inspection Points	25
7-3. Maintenance Procedures	26
7-3-1. ATC Grease Up	26
7-3-2. Tool Side Electric Contact Pin Replacement	27
7-3-3. Replacement of Robot Side Pneumatic Port O-ring	28
7-3-4. Chuck/Unchuck Sensor Conduction Check	28
7-3-5. Tapered Pin Replacement	29
7-3-6. Bush Replacement	29
7-3-7. Tool Adaptor Lock Pin Replacement	29

8. Recommended Spare Parts	30
9. Backup Item	30
10. Troubleshooting	31
10-1. Cause Effect Diagram	31
10-2. Trouble Symptoms and Response Actions	31
10-2-1. ATC Does Not Work	31
10-2-2. Unable to Exchange Signals with ATC	32
10-2-3. Air Leakage from ATC	33
10-2-4. Increased ATC Temperature	33
10-2-5. Tool (i.e. Gun and Hand) Does Not Work	34

Preface

Thank you for choosing Nitta Automatic Tool Changer (hereafter referred to as "ATC").

This instruction manual provides precautions for handling, detailed descriptions of the specifications and mandate inspection and maintenance items for secure applications and appropriate maintenance and inspection of the system, focusing on mechanical sections of ATC. Therefore, those in charge of introduction line planning, maintenance and inspection, unpacking or actual operations of the product must read this document and fully understand the ATC before use.

Please keep this document always readily available to those who use the product.

- All rights reserved.
- External appearance and specifications described in this document are subject to change for improvement.
- Be sure to read this document carefully before working on the product.
- Be sure to confirm whether workers are required to be sufficiently trained for applicable expertise.
- Take note that we assume no responsibility regarding any damage or accident that occurs in works performed by customers.

Notice

This document is only intended for customers of Nitta Corporation (hereinafter referred to as "the company"). Technical information and drawings presented in this document are the proprietary of the company and it is prohibited to publish them to any third party without prior written consent of the company. The contents of this document are subject to change without any prior notice. The delivered product may not be the same as figures and photos contained herein due to any later change in specifications.

Product Warranty

- Warranty period

1 year from the delivery date of this product or 3,000 hours of operation, whichever comes first.

- Warranty subject

Any genuine part of the product exhibiting defect in material or manufacturing will be fixed or serviced without charge within the warranty period.

- Exclusion

Items listed below are excluded from warranty:

- (1) Any failure and accident arising out of user's negligence
- (2) Consumables
- (3) Any failure caused by natural disaster, accident, fire, theft or unauthorized use, etc.
- (4) Any failure or accident arising out of non-conformity to maintenance and inspection instructions set forth in this document
- (5) Any failure or accident arising out of repair, adjustment, or alteration performed by other than Nitta engineers
- (6) Any failure caused by any use of used parts

Any secondary damage such as line stoppage due to a system failure or damage arising out thereof is also out of the warranty coverage.

Unpacking and Check

Although we exercise thorough care to eliminate wrong delivery before shipment, please check the following items when you unpack the product for confirmation. Should there be any defect or missing item, please contact our office indicated in the cover page of this document.

- Please check that mounting bolts are included. (See the relevant delivery specifications.)
- Please check the spare parts. (To be determined in separate meetings.)
- For details of special options, please feel free to contact us.





Safety Precautions

For Safe Use of the Product

Hazard, warning and cautions indications in this document

This section describes safety precautions for proper use of the Nitta product and prevention of injuries and property damages. These precautions are classified into three levels according to severity of potential hazards and damages that may be caused by non-conformity thereto.

Indications in this document	
-------------------------------------	--

 DANGER	Improper use disregarding this indication may lead to a hazardous situation which may result in death or serious injury and requires urgent alerting when such hazard is materialized.
 WARNING	Improper use disregarding this indication may lead to a hazardous situation which may result in death or serious injury.
 CAUTION	Improper use disregarding this indication may lead to a hazardous situation which may result in minor injury or property damage.
 Referenc	This indicates use examples, etc.
 MEMO	This indicates special instructions less important than cautions.

Please note that a severe accident may occur depending on situations even when instructions in the indications are observed. Please strictly observe the instructions.

Disclaimer	<p>We assume no responsibilities for any damage arising out of any failure caused by intention or negligence of customer (including software malfunction), or any reason not attributable to Nitta, such as an accident or natural disaster.</p> <p>We assume no responsibilities for any damage caused by any use not described or prescribed in our catalogs (including the instruction manual).</p> <p>We assume no responsibilities for any failure alleged to be warrantable by customers if there is no clear evidence of our responsibility.</p> <p>We assume no responsibilities for any incidental damage arising out of use of or inability to use our product (including but not limited to loss of business profit and business interruption).</p>
------------	--

Introduction

ATC does not work alone and is only usable when being equipped on a robot and a compatible unit. For increased safety of the entire system, it is necessary to consider not only the single ATC but also the robot system and compatible unit system as a whole.

 **DANGER**

For use of ATC, be sure to observe safety instructions concerning core robots and compatible units. For any work within the robot safety fence, consider preparing a safety system design to shut down power over 50V once any person gets into the fenced area.

General Precautions

⚠ CAUTION Personnel engaged in installation, programming and maintenance works inside the robot safety fence for the ATC must have expertise in robot operations (having completed expert training). In addition, those engaged in disassembly or assembly works of the ATC, whether in or out of the safety fences, shall read this document, installation guide, and maintenance procedures.

⚠ WARNING In addition, for works in the safety fence area, be sure to wear appropriate clothing for the work with personal protective equipment such as a hard hat, safety boots, etc. For internal disassembly works for the ATC, use protective glasses for protection against pop-out parts.

⚠ WARNING Do not use this product in any of the environments listed below. Otherwise, operators may be injured.

- Flammable environment (containing highly volatile and flammable substances)
- Environment with explosive atmosphere (e.g. combustible gas and chemical spattering)
- Environment exposed to water/water drops or highly humid environment
- Environment with corrosive atmosphere
- Environment with high degree of radiation

When the product is used under any of the above environment, we assume no responsibility for any failure or damage.

Also, malfunction may occur in an environment with spattering dust, chip and cutting oil, etc.



Precautions for Installation

⚠ WARNING For installation of the ATC, remove the pertinent product and place it out of the robot safety fence as long as possible so that installation can be performed securely.

⚠ DANGER If installation work is performed inside the safety fence, securely shut off the power over 50V from the ATC and ensure that the robot is securely stopped before entering into the fence area.

⚠ DANGER Be sure to check the following items before starting the installation procedure:

- (a) Welding power source, control power source and driving power source are all shut off before work.
- (b) All hydraulic and pneumatic pressure sources are off before work.
- (c) All residual hydraulic and pneumatic pressure is released before work.
- (d) Note that some connectors and cables may be hot depending on their specifications.

 DANGER	Turning the power supply or hydraulic/pneumatic pressure source ON during the installation work without notifying the operator(s) may create an extremely dangerous situation. Establish a procedure to always prevent such events for safety in work areas.
 CAUTION	Be sure to install specified parts. In addition, when you replace parts, install parts to their original positions and be sure to perform inspections in accordance with certain procedures.
 WARNING	Ensure that the rated load (moment torque) does not exceed product's rated value. Otherwise, not only the product functionality and life may be adversely affected but also unexpected accident may occur.
 WARNING	Ensure that the electric load applied to the signal pin and electrode does not exceed the rated voltage and allowable current. Otherwise, not only the product functionality and life may be adversely affected but also unexpected accident may occur.
 WARNING	Supply water and air to hydraulic/pneumatic and ATC chuck/unchuck ports so as to maintain pressure within the rated range. Otherwise, not only the product functionality and life may be adversely affected but also unexpected accident may occur.
 MEMO	<ul style="list-style-type: none"> - To install a robot adaptor, set the robot mounting surface facing up, rather than horizontal. Then robot adaptor installation becomes relatively safer. - When installing a tool adaptor, set tools on the tool stand. Then tool adaptor installation becomes relatively safer.
 WARNING	Switch air supply to a chuck/unchuck port in the detached state to check that the coupling cam motions are correct. Operating without doing this may cause tool falling, product damage, or unexpected accident.
 DANGER	When manually switching air supply of the chuck/unchuck port, set tools on the tool stand. Otherwise, improper motions or piping may cause tool falling, product damage, or unexpected accident.
 CAUTION	Arrange cables and tubes without causing catching during robot motions. Otherwise, the ATC and its functional modules may be damaged.

Precautions for teaching

 **WARNING** With the tool detached, check that the interlock signals output from the ATC are correct. Operating without doing this may cause tool falling, product damage, or unexpected accident.

 **WARNING** For chuck/unchuck, switch air supply for chuck/unchuck with the coupling planes of robot side and tool side adaptors are horizontally coherent on the tool stand. Otherwise, an unexpected accident may occur due to tool falling, in addition to damage to the ATC and its functional modules due to prying.

 **DANGER** When the welding power is on, there is a risk of electricity leakage. Do not touch any component connected with the ATC.

Precautions for Long-Term Shutdown or Transportation

 **DANGER** The failsafe mechanism serves to prevent falling. Do not continue using the product when the air pressure is decreased. Otherwise, the gap between contact surfaces of robot and tool adaptor is increased and unexpected accident may occur.

When the tool is left coupled by the failsafe mechanism only for a prolonged period of time, the gap between contact surfaces of robot and tool adaptor is increased by vibration, etc. and unexpected accident such as falling may occur.

If it is absolutely necessary to stop the air supply for a long time with the tool coupled, be sure to take measures against falling, e.g. fixing it by rope, etc.

1. Overview of the Automatic Tool Changer (ATC)

A pneumatic-driven system is employed for the Nitta ATC. Basically, the ATC consists of 2 components: a robot adaptor and a tool adaptor. The ATC is compatible with all the robot tools with respective adaptor plates (optional). In addition, the ATC is equipped with transmission mechanisms such as a signal pin to transmit signals and power source to the tool, and pneumatic port.

1-1. Robot Side

1-1-1. Robot Adaptor

The robot adaptor is a basic component of the ATC. Each robot adaptor is equipped with sensors that transmit signals (chuck end signal, unchuck end signal and coupling check end signal) to communicate its attachment conditions.

[Chuck/Unchuck Mechanism]

The cam mechanism to connect a robot adaptor and tool adaptor together is of a special structure, which is designed to automatically compensate for misalignment at the time of jointing and wear allowance to be generated over time. These cams are operated by an air cylinder and designed not to come off under temporary loading above the rated load.

Under such load, the contact surfaces of the robot adaptor and the tool adaptor will be slightly separated, but the adaptors will never be completely separated. Also, these cams are driven by a spring-return pneumatic cylinder, as a fail-safe mechanism to prevent falling of the tool adaptor even in the event of sharp reduction of the air pressure.



DANGER

The failsafe mechanism serves to prevent falling. Do not continue using the product when the air pressure is decreased. Otherwise, the gap between contact surfaces of robot and tool adaptor is increased and unexpected accident may occur.

When the tool is left coupled by the failsafe mechanism only for a prolonged period of time, the gap between contact surfaces of robot and tool adaptor is increased by vibration, etc. and unexpected accident such as falling may occur.

If it is absolutely necessary to stop the air supply for a long time with the tool coupled, be sure to take measures against falling, e.g. fixing it by rope, etc.

[Chuck/Unchuck Sensor Signals]

Chuck end signal (coupling end)

Signal that indicates the cam is not fully engaged. When this signal and a coupling check signal are both active, the robot can pick the tool adaptor from the tool stand.

Unchuck end signal (detachment end)

This signal indicates that a cam to lock (couple) the robot adaptor and tool adaptor is drawn into the robot adaptor. While this signal is active, the robot adaptor may approach the tool adaptor freely and leave the tool adaptor after completion of tool replacement on the tool stand safely.

Coupling check end signal (face end)

This signal indicates that jointing planes of both the robot adaptor and tool adaptor are in contact. This signal indicates that both adaptors are in parallel and their contact surfaces are sufficiently close to each other, and that the cam is positioned appropriately to move for the chuck/unchuck operation with no problem.

[Transmission Mechanism]

The ATC has six pneumatic ports and 15 electric signal pins (standard spec).

1-1-2. Robot Adaptor plate

A robot adaptor plate is to be used to attach a robot adaptor to a robot used. No processing of holes and screws for installation to a robot is performed on standard products. (We may perform such processing upon your request. You may also prepare a robot adaptor plate on your own.) For details on attachment of robot adaptor and robot adaptor plate and associated precautions, please refer to this document and the delivery specification drawing.

1-2. Tool Side

1-2-1. Tool Adaptor

A tool adaptor is another fundamental component of the ATC, to which a tool is attached. A tool adaptor is equipped with lock pins to be engaged with robot adaptor's locking cams.

1-2-2. Tool Adaptor Plate

A tool adaptor plate is to be used to attach a tool adaptor to a tool used. No processing of holes and screws for tool attachment is performed on standard products. (We may perform such processing upon your request. You may also prepare a tool adaptor plate on your own.) For details on attachment of tool adaptor and tool adaptor plate and associated precautions, please refer to this document and the delivery specification drawing.

1-3. Options

For details of options, e.g. non-standard signal pin modules, spot welding modules, and pneumatic modules, please feel free to contact us.

2. Composition

This system is composed of the ATC and electric block ASSY assembled thereto. An electric block ASSY is a 15-core contact-type electric contact using spring contact pins, which can be optionally scaled up to 20 cores.

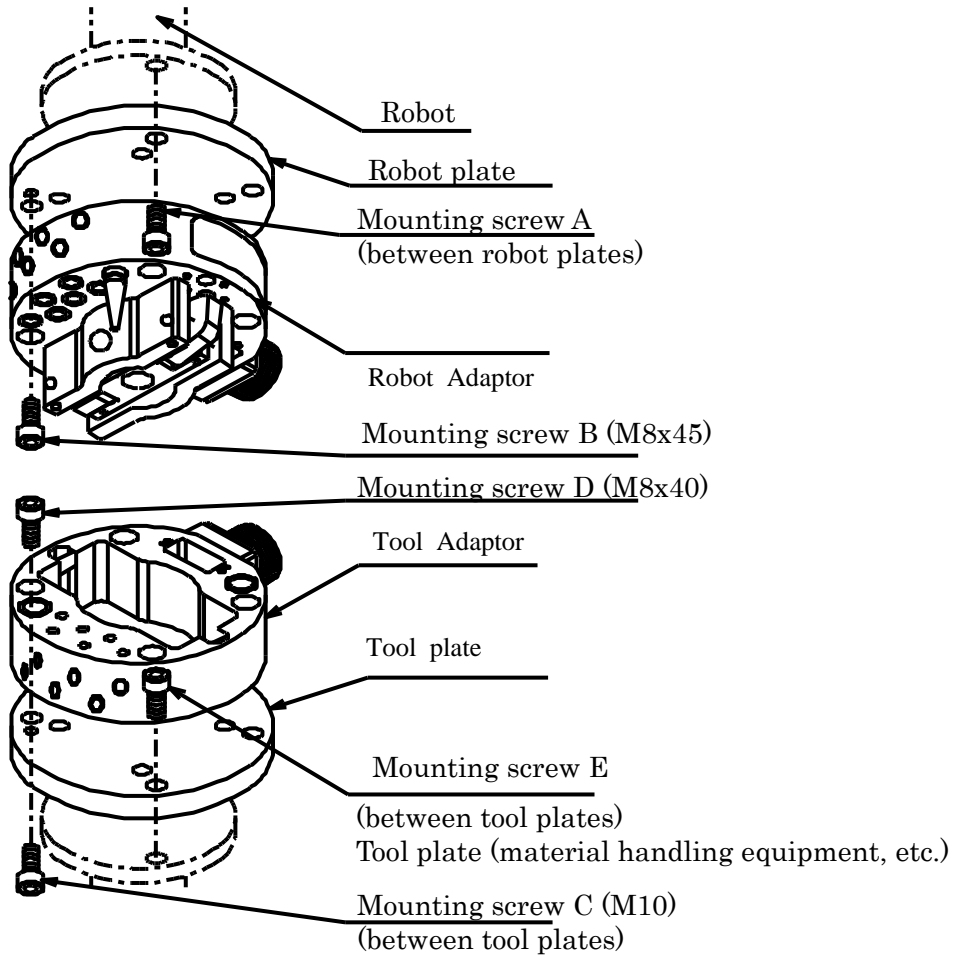
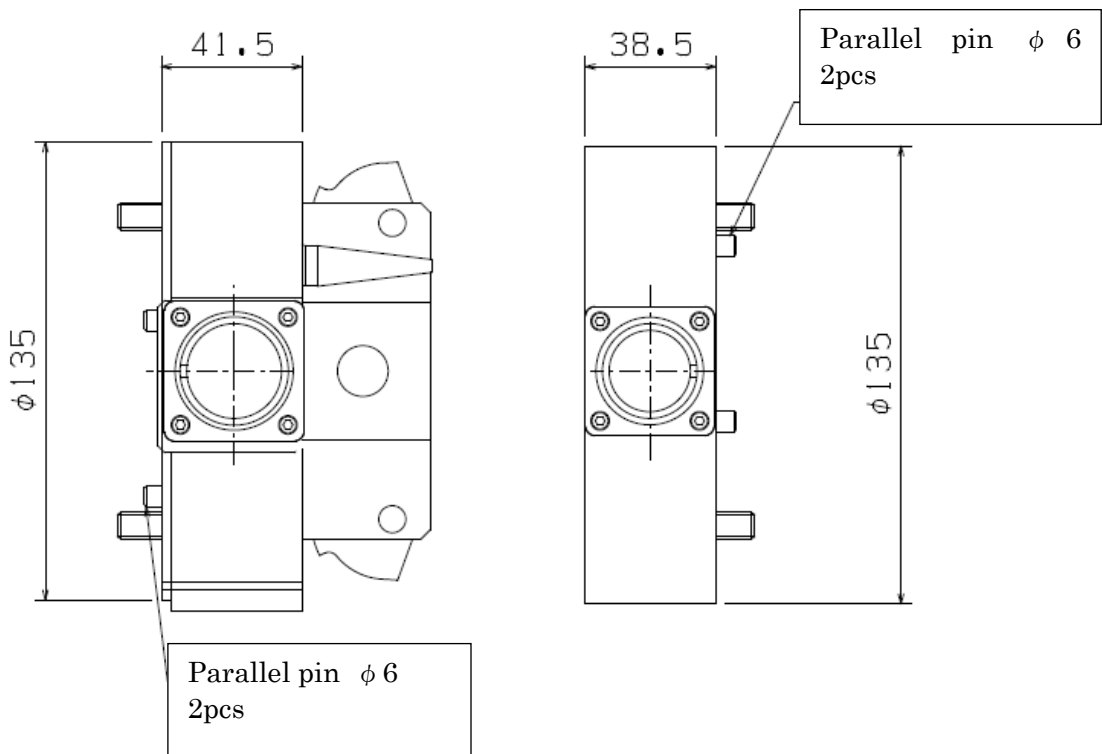

Fig. 1. System diagram

3. Standard Specifications

3-1. ATC Specifications

Specification			
1. Type	Robot Adaptor	See the drawing	
	Tool Adaptor	See the drawing	
2. Load mass (under maximum load)	Payload	60kg	
	Allowable moment	441Nm (4500kgf·cm)	
	Allowable torque	441Nm (4500kgf·cm)	
	Working pressure	0.39-0.59MPa (4-6kg/cm ²)	
3. Position reproducibility		±0.025mm	
4. Interface	Electricity	Number of electric contacts	See the drawing
		Capacitance	3A
	Air	Number of hydraulic ports	6
		Normal pressure	0.855MPa (8.75kg/cm ²)
		Effective sectional area (CV value)	11 mm ² (0.63)/port (Rc1/8 ports)
5. Mechanical mass	Robot Adaptor	1.0 kg	
	Tool Adaptor	0.5kg	
6. Machine dimensions	Robot Adaptor	See the drawing	
	Tool Adaptor	See the drawing	



3-2. Chuck/Unchuck Sensor Specifications

3-2-1. Coupling Check End Sensor

Name	General-type proximity switch (Yamatake)
Model	FL7M-2J6HD-903
Type	DC 2-wire type
Connection type	Prewired (M8)
Rated operation distance	2±0.2mm
Setting distance	0-1.4mm
Standard detection object	8x8, t=1mm, iron
Hysteresis	Up to 15% of the operation distance
Response frequency	2kHz
Operation mode	N.O. (normally open)
Switching capacity	3-100mA
Protection circuit	Load short-circuit protection, prevention of reverse connection, and surge absorption
Rated power supply voltage	12-24VDC
Leak current	0.55mA or below
Protection structure	IP67 (IEC standard) and IP67G (JEM standard)
Ambient temperature	-25 to +70°C
Insulation resistance	50MΩ or above (at 500VDC)
Withstand voltage	1,000VAC; 50/60Hz 1 minute: all live parts and between cases
Vibration resistance	10-55Hz; double amplitude 1.5mm; X, Y, and Z directions; 2 hours
Impact resistance	980m/S ² ; X, Y, and Z directions; 10 times

3-2-2. Lead Switch for Chuck and Unchuck

Name	Contact-less auto switch (SMC)	
Model	D-F7BV	
Type	DC 2-wire type	
Detection object	Magnetic object	
Hysteresis	1mm or less	
Operation mode	N.O. (normally open)	
Rating	Power supply voltage	24VDC (10-28VDC)
	Leak current	1mA or below (24VDC)
	Internal voltage drop	3.0V or below
Environmental resistance	Protection structure	IP-67 (IEC standard)
	Ambient temperature	-10-60°C (no freezing)
	Insulation resistance	50MΩ or above at 500VDC
	Impact resistance	About 102G

3-3. Fall Protection System Specifications

Product No.	CAR-006-**
External dimensions (height x width x thickness)	64x70x73mm
Main unit material	Aluminum alloy
Weight	0.98kg
Effective sectional area (Cv value)	6mm ² (0.33)
Fluid used	Air
Working pressure	0-0.99MPa
Ambient temperature and working air temperature	0-60°C
Joint diameter (nominal)	Rc(PT)1/8(6A)
Grease up	Not required/Class 1 turbine oil if used (ISOVG32)

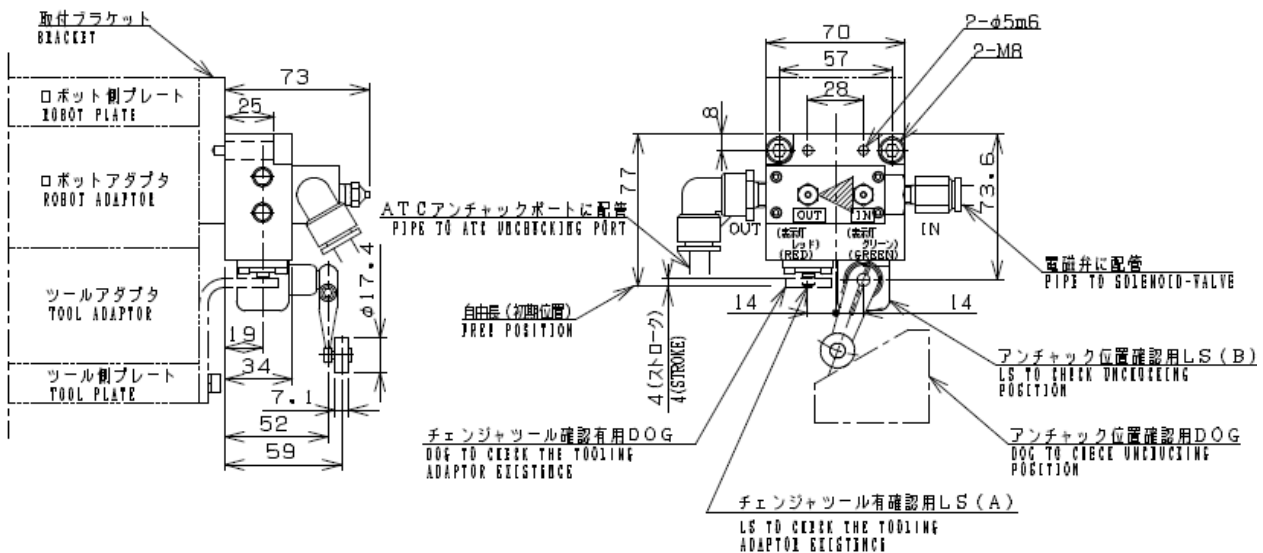

(Refer to the delivery specifications for details.)

⚠ CAUTION

- Ensure that there is no problem with piping.
- Ensure that the lever and DOG positions are as per the delivery specifications.

⚠ WARNING

Perform installation carefully not to bend the tube connected with the chuck/unchuck port during robot motions. Otherwise, it may fall off.

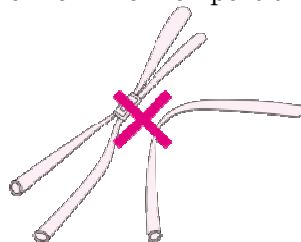

- Tube bending
- Tube twisting
- Excessive tightening of tube with banding band

3-4. Precautions for Allowable Load and Installation

⚠ WARNING

Rated load, rated moment, and rated torque of the ATC are dynamic specifications for the unit being mounted on a robot.

Ensure that the maximum load never exceeds these values during normal operations taking into account the acceleration factor and inertia during acceleration/deceleration by the robot.

Figure 2 shows the meanings of rated load, rated moment and rated torque.

Payload	$W = 60\text{kg}$
Eccentric distance	$L = \sqrt{Lm^2 + Lt^2}$
Allowable bending moment	$M = L \times W \times G_R^{(*)} = 50/100 \times 60 \times 1.5 \times 9.8 \leq 441\text{N}\cdot\text{m} \{4500\text{Kgf}\cdot\text{cm}\}$
Allowable twisting torque	$T = L \times W \times G_R^{(*)} = 50/100 \times 60 \times 1.5 \times 9.8 \leq 441\text{N}\cdot\text{m} \{4500\text{Kgf}\cdot\text{cm}\}$

Note: $G_R^{(*)}$ is the acceleration factor of constant acceleration/deceleration in automatic robot operations. For specific values of robot performance, please contact the robot manufacturer for further consideration. (Use 1.5-2.0G as a standard.)

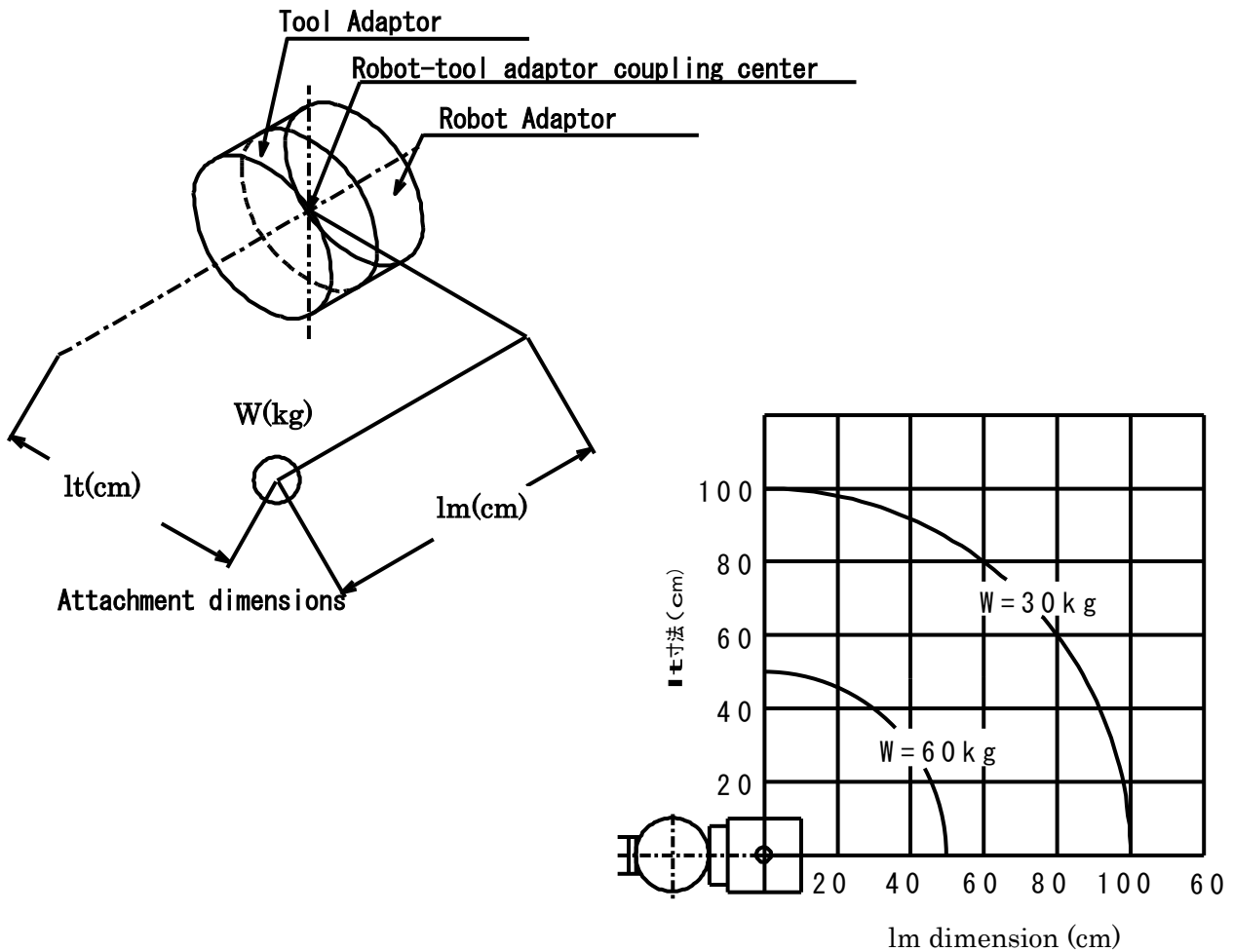

Fig. 2. Definition of rated load

3-5. Allowable Electric Load

⚠ CAUTION

The ATC with the standard signal pin ASSY (15-pin), as an entire contact ASSY, is capable of carrying up to 15A current. Also, each of the pins is capable of carrying 110V 3A current. However, when multiple signal pins are to be used, do not let 3A current applied to any adjacent pin as it will cause insufficient insulation, leading to short circuit.

4. Part Names

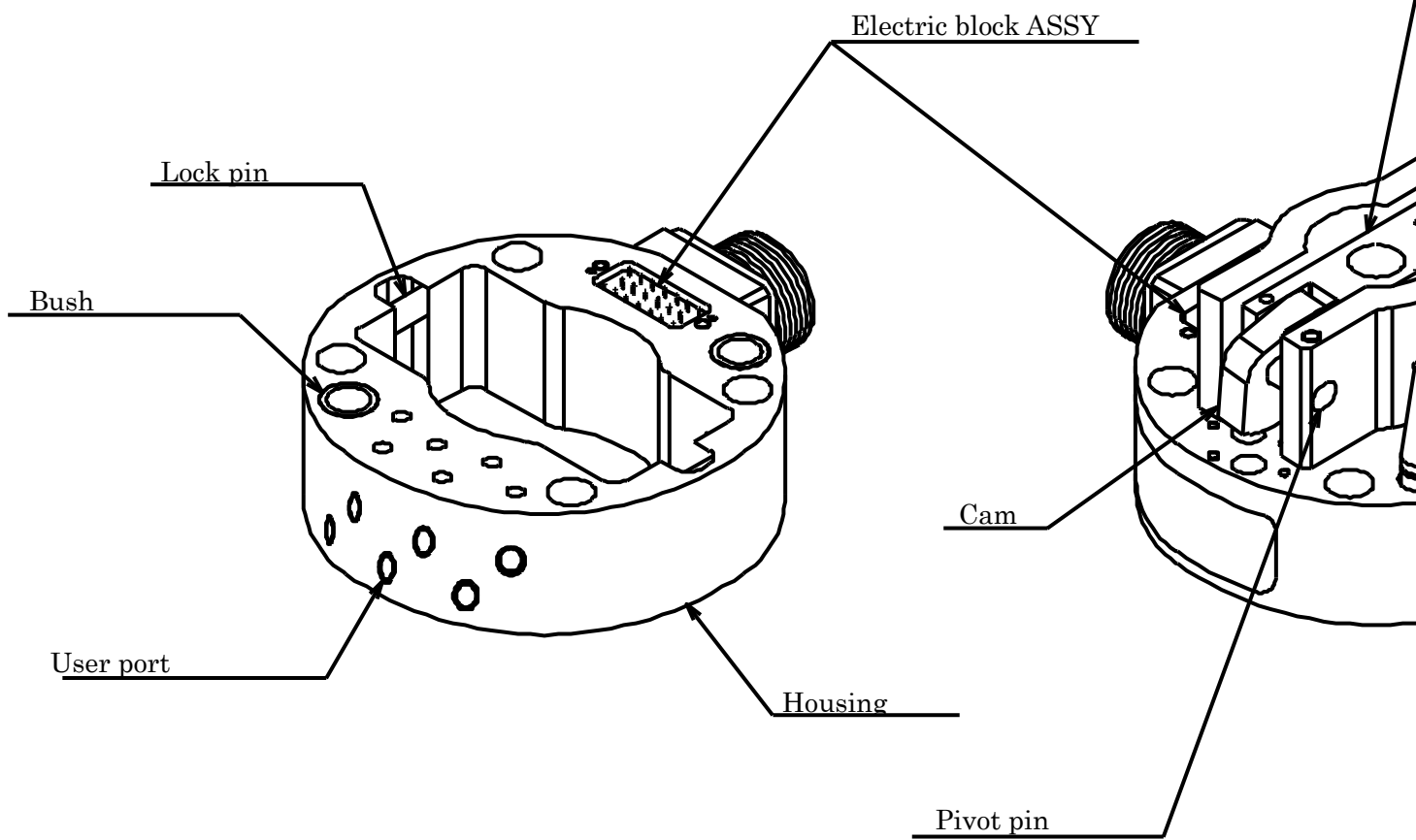

Fig. 3. Part names

5. Procedures of Installation to Robot/Tool

 **DANGER**

For use of ATC, be sure to observe safety instructions concerning core robots and compatible units. For any work within the robot safety fence, consider preparing a safety system design to shut down power over 50V once any person gets into the fenced area.

 **WARNING**

In addition, for works in the safety fence area, be sure to wear appropriate clothing for the work with personal protective equipment such as a hard hat, safety boots, etc. For internal disassembly works for the ATC, use protective glasses for protection against pop-out parts.

 **CAUTION**

Personnel engaged in installation, programming and maintenance works inside the robot safety fence for the ATC must have expertise in robot operations (having completed expert training). In addition, those engaged in disassembly or assembly works of the ATC, whether in or out of the safety fences, shall read this document.

5-1. Robot Adaptor

To install a robot adaptor to a robot, remove the robot adaptor plate from the robot adaptor and drill the robot adaptor plate to make appropriate mounting holes (or threads) for the robot. Then mount the robot adaptor plate to the robot first and then mount the robot adaptor on it. (Refer to Fig. 1. System diagram.)

Mounting bolts M8x45 4 pcs. [Torque: 30Nm]

5-2. Tool Adaptor

To install a tool adaptor to a tool, remove the tool adaptor plate from the tool adaptor and drill the tool adaptor plate to make appropriate mounting holes (or threads) for the tool. Then mount the tool adaptor plate to the tool first and then mount the tool adaptor on it. (Refer to Fig. 1. System diagram.)

Mounting bolts M8x40 4 pcs. [Torque: 30Nm]

The tool adaptor may also be fixed from the backside with M10 bolts. (See a relevant drawing in the delivery specifications.)

 **CAUTION**

Our robot and tool adaptor plates are temporarily assembled with a respective robot and tool adaptor in plant but their screws are not fully tightened. Before installation, therefore, please remove the mounting screws of the robot/tool adaptor even if there is no need for separating the adaptor from a respective plate.

 **CAUTION**

If you manufacture (process) a robot/tool adaptor plate on your own, be sure to ensure sufficient depth of counterbore so that the head of any mounting screw will not protrude from the mounting surface of each adaptor plate. When using male screws from the tool side to attach a tool to a tool adaptor, adjust the bolt length so that the tip of any male screw will not protrude from the tool adaptor plate surface.

⚠ CAUTION Check that a parallel pin ($\phi 6 \times 2$) is inserted to the mounting surface of the robot and tool adaptor before attachment. (See 3-1. ATC Specifications.) For details, please refer to the delivery specifications (robot and tool adaptor drawings).

⚠ CAUTION Be sure to use locking agent (low strength) for mounting bolts when tightening them.

Tighten bolts in the order of the numbers in steps so that equal force is applied to each bolt.
E.g. Tightening screws in a criss-cross pattern starting with ①, ②, ③ and so on.

For the installation work, set the robot flange surface facing upward at the height of your breast to prevent ATC from falling.

⚠ CAUTION

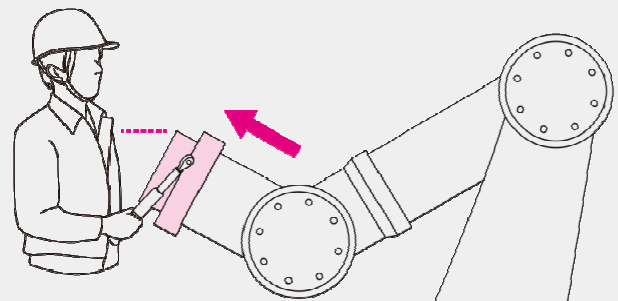
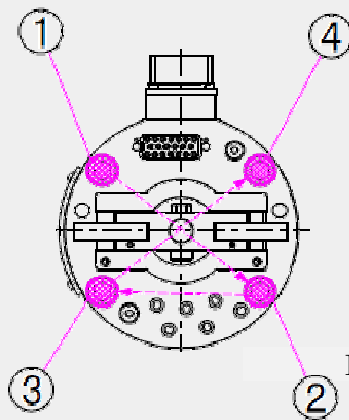

Bolt tightening sequence and precaution

⚠ CAUTION Tightening bolts with torque above the specified torque level may damage threads on the ATC side and modules.
Further, tightening bolts with torque below the specified torque level or failure to use the locking agent may cause bolts to be loosened, leading to module fall off.

5-3. Connecting to Chuck/Unchuck Port

Connect the single-acting 4-way solenoid valve with the "CHUCK" and "UNCHUCK" ports of the chuck/unchuck mechanism. The constant pressure line (with the valve not energized) must always be connected with the "CHUCK" port to maintain coupling of the chuck/unchuck port in the event of power failure.

⚠ WARNING

Be sure to shut off the power supply, air, water and hydraulic power before starting the work.

- Be sure to connect chuck (CH) and unchuck (UN) tubes properly. Otherwise the tool may fall off.
- Mark the chuck (CH) and unchuck (UN) tubes accordingly.
- Securely insert the tubes to the end to prevent disconnection.
- Do not manually switch the air supply without an absolute need to do so.

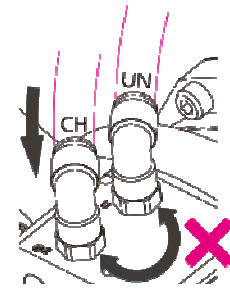

⚠ WARNING

Leave the "UNCHUCK" port opened without plugging even when chuck/unchuck is not to be performed (in a coupled state only). Also, be sure to pressurize the "CHUCK" port when using it. Otherwise, it may fall off.

⚠ DANGER

About air piping for ATC driving:

ATC has a fail-safe mechanism to prevent the tool side from falling even when air pressure is unexpectedly decreased. However, the air piping for ATC driving requires proper selection and arrangement of solenoid valve to prevent air from flowing into the "unchuck" side even when the valve is electrically turned OFF.

- Do not use any three-position, closed-center type solenoid valve. The chucked state cannot be maintained with the power supply turned OFF, which may result in falling.
 - Do not share an exhaust port with other equipment. Otherwise, the chucked state cannot be maintained due to wrap-around back pressure, which may result in falling.
 - Do not branch the air supply to the "CHUCK" port to other equipment. Otherwise, the chucked state cannot be maintained due to reduced pressure, which may result in falling.
-

⚠ WARNING Perform installation carefully not to bend the tube connected with the chuck/unchuck port during robot motions. Otherwise, it may fall off.

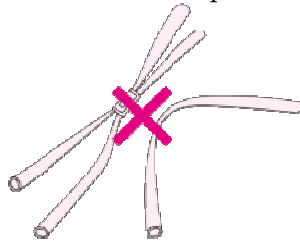

- Tube bending
- Tube twisting
- Excessive tightening of tube with banding band

⚠ WARNING Do not cap the exhaust port of the solenoid valve used for switching pressure on the chuck/unchuck port. Otherwise, it may fall off.

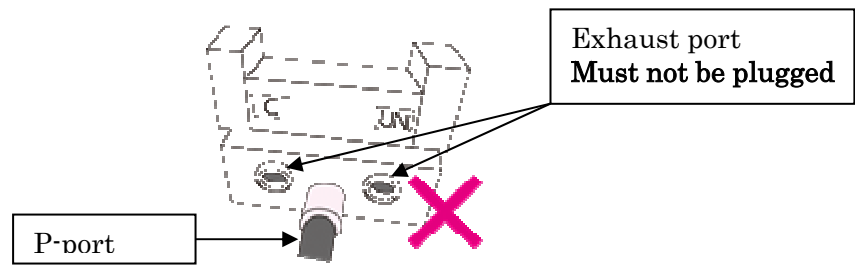

⚠ CAUTION As a solenoid valve used for switching pressure on the chuck/unchuck port, select a double-solenoid type valve. Then effects of any noise malfunction are mitigated.

5-4. Electric Wiring

With reference to the internal wiring chart, connect the input and output wires to robot adaptor terminals. Connect the built-in sensors to a robot (line, etc.) control system. Signals from these sensors will be taken through the aforementioned terminals. In case of the connector spec, be sure to securely insert the connectors.

⚠ WARNING Perform wiring as per the delivery specifications. Improper wiring may cause failure or electric leakage, etc.

⚠ WARNING Securely apply Class III grounding for earth and shield lines. Otherwise, electric shock and noise may occur, leading any malfunctions.

5-5. User Air Piping (Standard)

Install air piping to the robot adaptor as per the work (tool/gun, etc.) specifications. These ports are equipped on the robot adaptor as standard equipment.

⚠ CAUTION Ensure no chips of sealing tape on the relay, etc. get into the module. Otherwise, it gets into the O-ring sealing section inside and causes leakage.

⚠ CAUTION Use SUMIPLEX BN NO.1 (manufactured by Sumico Lubricant) or equivalent grease on the module port surface. Without lubrication, early breakage and leakage may occur.

◆ MEMO If you take measures for water quality management, i.e. using a filter for coolant, change of corrosion within the module is reduced.

5-6. Cable Fixing

⚠ CAUTION Robot side cables must be securely tied together with other cables and tubes and fixed around the robot adaptor's connector part by using a spiral tube or banding band, etc. Also ensure that cables and tubes are free of any excessive force while the robot's wrist axis is rotating. Excessive force applied onto cables and tubes may break a connector of the joint part or cause open-circuit. An example of cable fixing by a bracket is shown in Fig. 4.

📖 Referenc

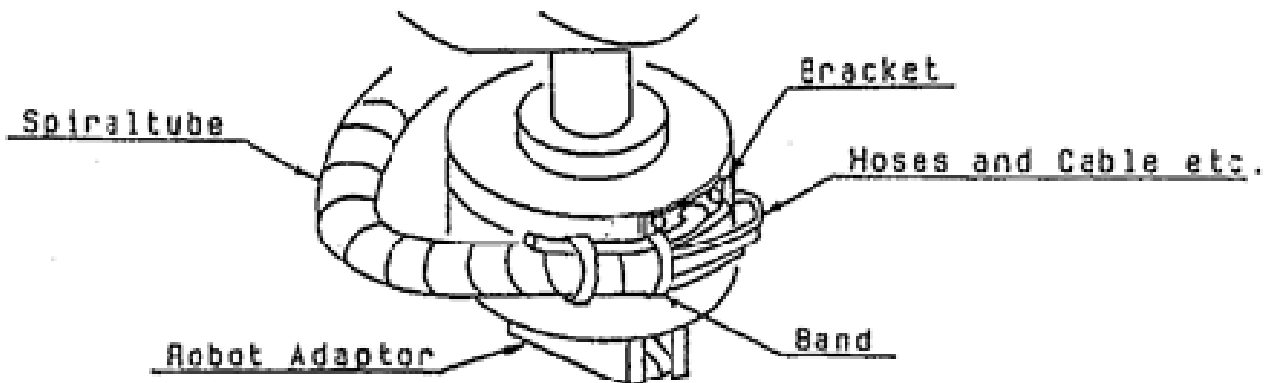

Fig. 4. An example of cable fixing

5-7. Precautions for Installing ATC to a Tool, etc.

5-7-1. ATC Orientation



MEMO

It is recommended to ensure that ATC is oriented so that its load center is in the same direction as the ATC's cam in order to minimize a gap between mating surfaces.

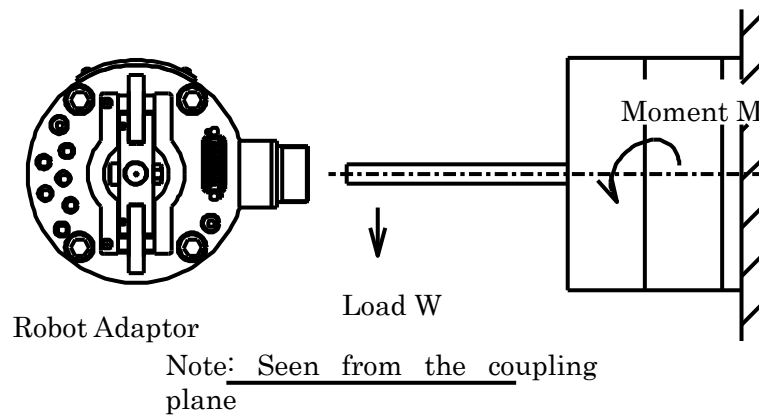

Fig. 5. ATC orientation

5-7-2. Proximity of ATC



MEMO

The ATC may be detached manually in case of emergency by following the procedure described later. However, if the lock pin holes, etc. on the tool adaptor are capped with a terminal box on the tool, etc., jigs may not be inserted and compulsory detaching is prevented. Ensure that there is not interference.

6. Operations and Programming

6-1. Checking before Teaching (Robot Operations)

⚠ CAUTION

Ensure that cables and tubes (hereinafter cables, etc.) are routed and fixed to the bracket without breaking. Also, ensure that the cables, etc. are fixed so that they do not interfere with peripheral components and work pieces during robot operations. *See 5-6. Cable Fixing.

⚠ CAUTION

Ensure that grease is applied to the shaded points.
*See 7-3-1. ATC Grease Up

⚠ WARNING

1) Ensure that air supply is not shut off by bending/twisting of the unchuck tube and excessive tightening of the banding bands. When the air supply is inhibited, the cam may not work properly resulting in tool side module falling.
2) Check that the unchuck port air is discharged before coupling (no residual pressure). Any residual pressure may prevent normal cam operations and cause the tool side modules fall off.

1) Tube

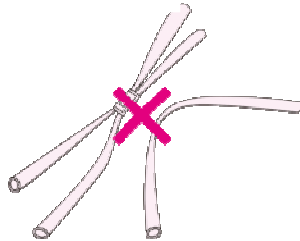

- Tube bending
- Tube twisting
- Excessive tightening of tube with banding band

2)

Solenoid

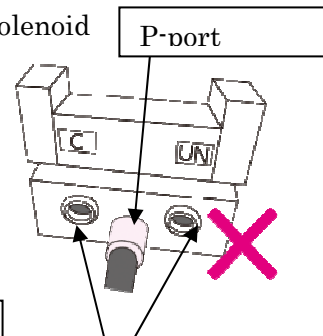

Exhaust port
Must not be plugged

⚠ WARNING

When operating a robot with a tool coupled, be sure to supply air to the chuck port.

6-2. Operations and Programming

This section describes a simple example of external interlock signals of the ATC. The ATC requires synchronization with a robot and peripheral devices and exchange of operation check signals to ensure reliability and safety. The ATC has three built-in sensors for detection of its own motions. For details, please refer to "1. Overview of the Automatic Tool Changer (ATC)."

WARNING

Configure interlock settings for chuck (*1), unchuck(*2), face (*3) and tool presence signals, etc. of the ATC. Check that the cam opening/closing is properly detected by the three face sensors and the respective LED lamps (*4) light up accordingly. Check that interlock signals are input to the superior control devices, such as PLC. Without setting of external interlock signals, safety may not be ensured in the event of operator errors or malfunction, posing a risk of tool falling.

*1. Chuck signal: Indicates that cam is opened

*2. Unchuck signal: Indicates that cam is closed

*3. Face signal: Indicates that coupling planes of the robot adaptor and tool adaptor are closely mated together

*4. LED lamps: Light up in different patterns to indicate the above signal output patterns

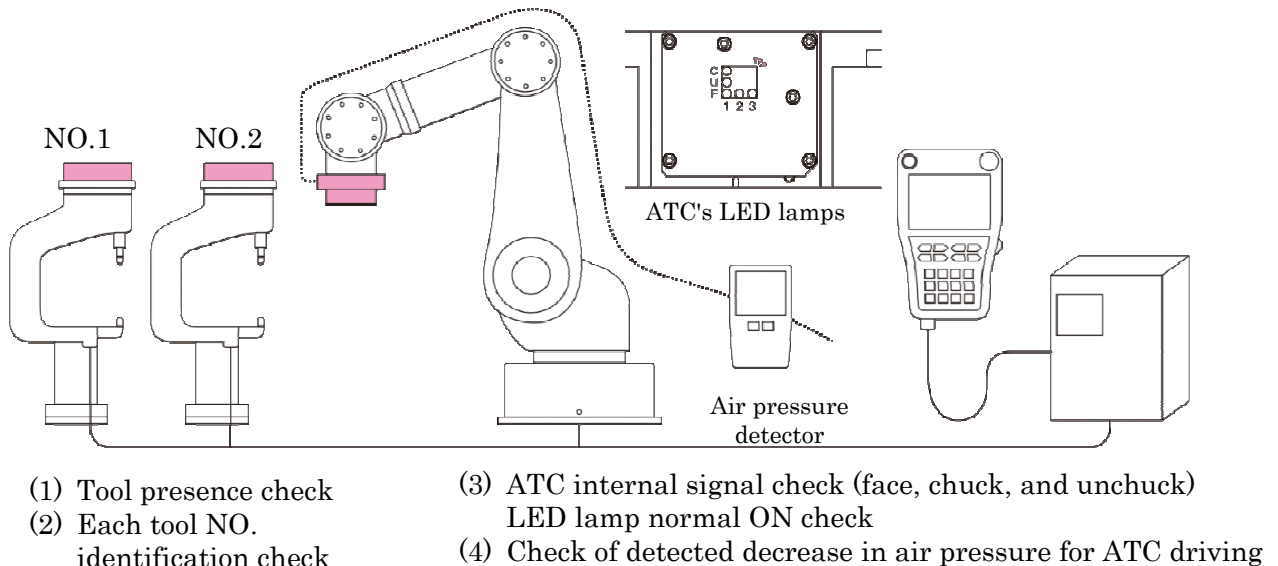

Fig. 6. Example of interlock

- The illustration above shows an example interlocking scheme for your reference. Please design safe interlocking scheme appropriate for your facilities.
- We offer specs with fall-protection mechanical valve or safety switch. (For details, please feel free to contact us.)
- If you do not choose to have our fall-protection mechanical valve or safety switch, be sure to introduce an appropriate safety system separately.

6-3. Basic ATC Flow

Ensure the robot interlock with reference to the flow indicated in Chart 1

Robot operation		Input			Robot output signal		External input
		ATC chuck/unchuck sensor			Electromagnetic valve for control panel		Fixture LS
		Coupling check end	Chuck	Unchuck	Chuck	Unchuck	Tool side presence
Coupling	Robot SB pos.	OFF	OFF	ON	OFF	ON	ON
	↓	↓	↓	↓	↓	↓	↓
	Robot movement	↓	↓	↓	↓	↓	↓
	↓	↓	↓	↓	↓	↓	↓
	Cplg pos. proximity	↓	↓	↓	↓	↓	↓
	↓	↓	↓	↓	↓	↓	↓
	Robot movement	↓	↓	↓	↓	↓	↓
	↓	↓	↓	↓	↓	↓	↓
	Coupling position	ON	↓	↓	↓	↓	↓
↓	↓	↓	↓	↓	↓	↓	
Chuck	↓	ON	OFF	ON	OFF	↓	
↓	↓	↓	↓	↓	↓	↓	
Cplg completed	↓	↓	↓	↓	↓	↓	
↓	↓	↓	↓	↓	↓	↓	
Robot movement	↓	↓	↓	↓	↓	OFF	
↓	↓	↓	↓	↓	↓	↓	
Robot work	↓	↓	↓	↓	↓	↓	
Separation	Robot work	ON	ON	OFF	ON	OFF	OFF
	↓	↓	↓	↓	↓	↓	↓
	Robot movement	↓	↓	↓	↓	↓	↓
	↓	↓	↓	↓	↓	↓	↓
	Separation point	↓	↓	↓	↓	↓	ON
	↓	↓	↓	↓	↓	↓	↓
	Unchuck	↓	OFF	ON	OFF	ON	↓
	↓	↓	↓	↓	↓	↓	↓
Robot movement	OFF	↓	↓	↓	↓	↓	
↓	↓	↓	↓	↓	↓	↓	
Sep. pos. proximity	↓	↓	↓	↓	↓	↓	
↓	↓	↓	↓	↓	↓	↓	
Robot movement	↓	↓	↓	↓	↓	↓	
↓	↓	↓	↓	↓	↓	↓	
Robot SB pos.	↓	↓	↓	↓	↓	↓	

Chart 1. Basic ATC flow

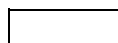

represents process stepping conditions.

- "Coupling check end ON" should be active during robot operations (during production).

WARNING

Continuous signaling is recommended for solenoid valve for chuck/unchuck. Please do not use one-shot signaling because it may not maintain the coupled state due to malfunction caused by any noise resulting in module falling.

6-4. Interlocking around ATC

For safe and smooth operations of ATC, it is recommended to configure the following signals.

1) Signal of detection of decreased air pressure for ATC driving

This signal notifies a robot of reduction of ATC driving air pressure for any reason, and robot operations will be halted when this signal is turned OFF.

2) Tool side presence signal

This signal detects the tool side unit of ATC (material handling equipment, etc.) is on the tool stand. This is an interlock signal to provide unclamping valve ON output, check that the ATC is securely located on the tool stand, and proceed with next robot step while checking that the entire tool side unit of the ATC is on the tool stand. This prevents the tool from falling in any unexpected situation.



WARNING

The tool presence signal is a very important interlock signal to tell the ATC can be detached safely.

Failure to use the tool presence signal as an interlock signal may cause the tool fall off during manual operations, leading to an unexpected accident.

3) Tool No. check signal

This signal is used by the ATC to check consistency between a coupled tool and running program No. when, for example, multiple robots are coupled with a tool from the same tool stand.

4) ATC operation check signal indicators

It is recommended to install indicators that constantly shows ON/OFF states of the aforementioned three signals (chuck end, unchuck end, and coupling check end signals) indicating the ATC operation status, and user signals used with the ATC (e.g. tool clamp end work presence).

This allows to readily comprehend any signal-related trouble and interlock waiting status.

6-5. Precautions for Operations

CAUTION

Basically, the connection surfaces of the robot adaptor and tool adaptor must be in parallel during the ATC attaching/detaching operation.

Otherwise, proper chuck and smooth unchuck may be prevented. Moreover, the electric contacts and hydraulic/pneumatic ports may be spoiled earlier.

If it is not possible to maintain parallelism with the robot and the tool stand, the tool stand must have an alignment function. On a tool stand with an alignment function, mate the flat planes by pressing the robot adaptor against the tool adaptor for proper teaching. (The alignment function must be designed to compensate for robot thrust, tool weight, flatness, and center deviation.)

Also, in the unchuck process, the tool adaptor may lean and cause prying due to reaction force of ATC's electric contact and pneumatic port, preventing unchuck. In such cases, the robot adaptor must be pressed against the tool adaptor as in the coupling process to prevent the tool adaptor from moving (deviating and leaning) right after unchuck. At this point, the tool must remain on the tool stand. Then, perform teaching so that the built-in sensors can detect unchuck and ensure smooth evacuation without prying.

MEMO

For the above, it is recommended to place ATC's tool stand on the level. However, if it needs to be upright due to a space constraint, please consider the following.

- 1) There must be no backlash of the tool adaptor's tool stand (besides the alignment function).
- 2) It must not move due to tool's offset load during unchuck or chuck of the tool adaptor.
(As far as possible, it should be supported near the tool adaptor.)
- 3) It must be pressed with sufficient pressure for coupling with the tool adaptor and have sufficient rigidity to prevent deflection of the tool stand. Also the anchor bolts must not be loosened or come off.
- 4) Tool side supports and tool side supported positioning sections of the tool stand must be abrasion resistant. It is desirable that parts can be replaced.

WARNING

Do not separate the robot adaptor carelessly when the tool adaptor is not in its home position on the tool stand.

Separating the tool adaptor while not in its home position may damage the ATC or peripheral equipment and/or hurt operators.

If the ATC is applied for demurring or other machining, position the tool stand so that no cutting chips and cutting oil are adhered to the tool adaptor.

If the stand position is exposed to adverse environment with spatters, water drops and dust particles, install an automatic cover or the like to protect the tool adaptor. Further, in oily atmosphere, ensure good conduction by, for example, air blow on the signal pin section.

We offer standardized peripheral devices for the ATC such as fall-protection system. For details, please feel free to contact us.

CAUTION

Be sure to attach/detach the ATC without pneumatic pressure applied to the user pneumatic port. Otherwise, user pneumatic O-ring may be damaged or come off.

6-6. Points to Check during Line Downtime (or Line Uptime)

⚠ WARNING

- Recommended usage

During the robot downtime, e.g. nighttime or holidays, keep the tool side module detached. During uptime, check that the cam is closed at the time of approaching for coupling of the tool side unit. Coupling operations performed with cam left opened may cause crash between the cam and lock pin, resulting in component damage.

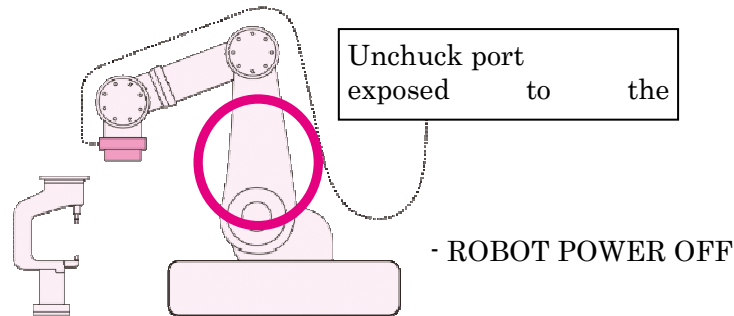

Fig. 7. Precautions for line downtime

⚠ DANGER

- Usage not recommended (only allowed if there is an absolute necessity)

If the tool side adaptor cannot be kept detached during downtime due to any reasons related to the facilities, take due care of the following.

If the line has to be stopped with the tool side module coupled, be sure to release the unchuck port regardless of air supply pressure presence. (No residual pressure allowed.)

If the unchuck port is not released, the cam may be operated due to air wraparound resulting in tool side module falling. Position the tool appropriately to prevent falling and turn the power and air supply OFF before stopping the equipment.

There may be residual air pressure when:

- air supply is shut off by bending/twisting of the unchuck tube or excessive tightening of the banding bands (see 6-1 in page 16): or
- the exhaust ports of the manifold and solenoid valve are plugged (see 6-1. in page 16).

Points to check before restarting the line:

- Ensure there is no gap between the coupling planes.

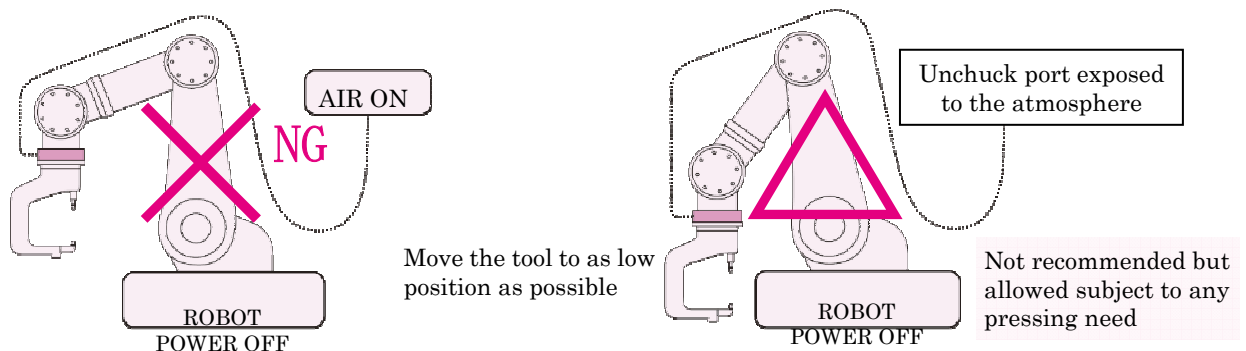

Fig. 8. Positions that should be avoided during line downtime

6-7. Emergency Response Actions

6-7-1. Manual Unchuck in Case of Emergency

The ATC has holes on the tool adaptor side to fold the cam toward the unchuck side.

- (1) For manual unchuck, ensure that the tool will not fall off during the unchuck process.

⚠ DANGER

Fall protection with sufficient strength must be implemented.

(For example, suspend the gun with a rope.)

- (2) Check that the unchuck port air pressure is applied.

- (3) Use a screwdriver or the like to move it backward without scratching the cam motion plane. At this point, folding one cam toward the unchuck side will cause a gap from the ATC mating surface and may result in prying on other cams. Make sure to minimize the gap sufficiently to prevent prying when reversing a cam.

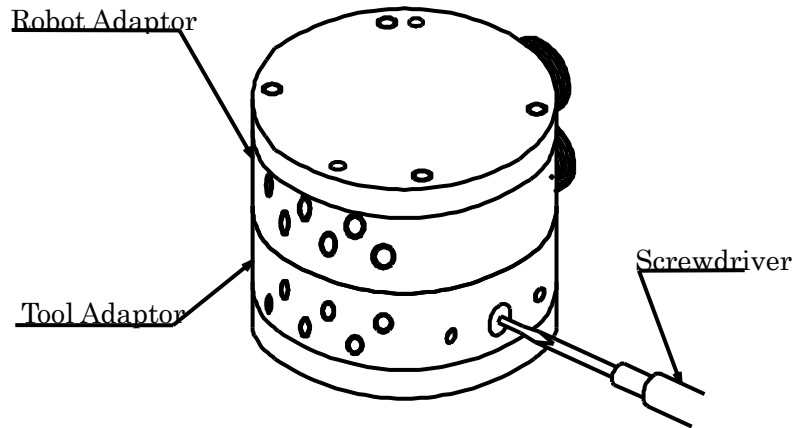

Fig. 9. Forced separation

6-7-2. Response Actions to Interference or Crash

CAUTION

In the event of interference or crash with a robot or a jig attached to the robot, e.g. a gun and transformer, be sure to take the inspection and response actions described in the chart below. A significant force is applied to ATC upon interference or crash, which may create any factor that shorten the product service life. Therefore, the inspection interval may need to be shortened as necessary. For ATC replacement and damaged part replacement, please refer to relevant sections of this document.

Chart 2. Response actions to interference or crash

	Check item	Check method	Response action to abnormality
1	Presence/absence of cracking	Visual	ATC replacement
2	Housing deformation	Visual	ATC replacement
3	Loose bolts	Mounting bolts	Re-tightening
4	Cam chuck/unchuck operations and signal system check	Turn the valve ON/OFF manually and check operations and signal ON/OFF.	ATC replacement
5	Presence/absence of gap of coupling planes	Visual: Cam surface damage; lock pin and pivot pin breakage and damage; and mating surface dent	Replacement of damaged parts
6	Presence/absence of rattle in the rotation direction	Visual: Tapered pin breakage; bush damage; and loose bolts	Replacement of damaged parts
7	Check for damage in electric signal pins and connector cables, etc.	Visual, and I/O panel signal check	ATC replacement and replacement of damaged parts

6-7-3. Response Action to Water Exposure

CAUTION

If the equipment is exposed with water, immediately stop using it and check if water enters into the product. Using the equipment with water presenting in internal electric component may cause signal output failure due to short-circuit. Moreover, when grease is washed out by water, sliding parts will be subject to higher friction, which can result in poor coupling or sealing. In the event of exposure to water, be sure to conduct the inspection and actions specified in the chart below.

Chart 3. Response action to water exposure

	Check item	Check method	Action
1	Electric contact and proximity SW signal	Check for short-circuit on the I/O unit side. Visually check for accumulation of water.	If any, wipe off with a dry cloth. (*Do not attempt to blow water off with an air gun or the like as doing so may let water get further into the equipment.)
2	Cam, lock pin and tapered pin	Visual check	Apply grease.
3	O-ring	Visual check	Apply grease.
4	Other section exposed with water	Check all sections for water accumulation and wipe off if any.	Apply grease to uncoated metal parts.

6-8. Precautions for Using a Servo Motor for a Tool



MEMO

When any tool equipped with a servo motor (a servo gun and tool, etc.) is used, the encoder is cleared after chuck/unchuck, so be sure to install a battery for memory on the tool side.

In addition, functionality to electrically disconnect/connect the servo motor is necessary on the robot.

6-9. Precautions for Transportation



WARNING

To move the system with the modules coupled together without air supply, use rope or the like to bind them and prevent tool side module from falling.

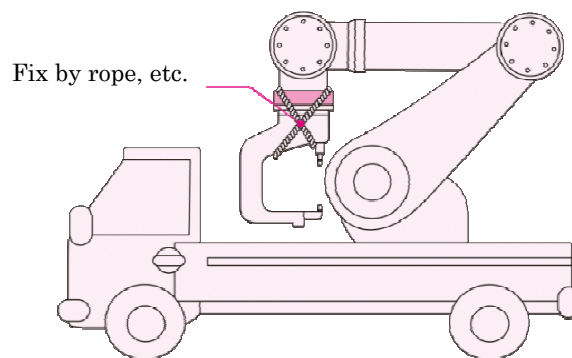

Fig. 10. Precautions for transportation

7. Maintenance and inspection

7-1. Maintenance and Inspection Schedule

Basically there are daily, monthly, quarterly, half-yearly, yearly, and 4-year (overhaul) inspections; additional inspection items are to be performed in inspections of longer intervals. For inspection items for different intervals, refer to the figure below. Appropriate inspection works not only improve the life of the mechanism but also are necessary to prevent failures and ensure safety. Be sure to strictly follow the regular inspection schedule. Inspection intervals are calculated based on standard single-shift time. Frequency should be estimated based on your robot's cycle time, etc. For example, in a two-shift system the monthly inspection must be performed twice in a month (every 10000 cycles).

Standard cycle time: $\text{Once/min.} \times 60 \text{ min.} \times 8 \text{ hrs./day} \times 22 \text{ days/month} = 10560 \text{ times}$

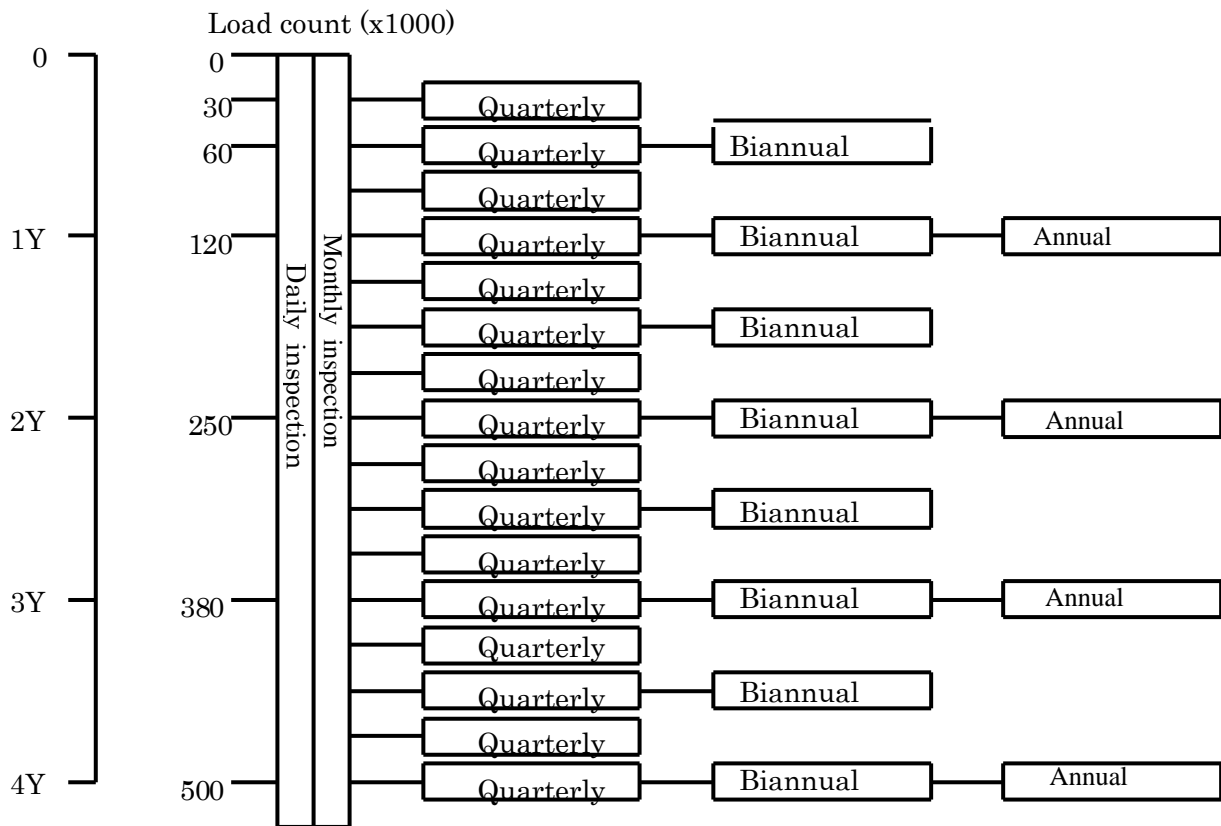

Fig. 11. Inspection schedule

7-2. Maintenance and Inspection Points

Inspection items are basically classified into daily inspection, monthly inspection, quarterly inspection, biannual inspection, annual inspection, and 4-year inspection (overhauling) as indicated in the following chart. Inspection items are listed in Chart 4. For working procedure of each inspection item, refer to the maintenance and inspection procedures described later.

Chart 4. List of inspection items

Interval	Item	Reference maintenance procedures
Daily inspection	Check for any foreign materials on the tool side and robot side signal pins. Ensure that the pin height is consistent	Visual
	Check that there is no air leakage when the units are coupled	Tactile
	Check that there is no gap between mating surfaces when the units are jointed (Check for any rattle)	Visual
	Check that no foreign matter adheres to the mating surfaces of adaptors of the robot and tool.	Visual
Monthly inspection	Grease up the cams, lock pins, tapered pins and bush air port O-rings.	See 7-3-1.
	Check that there is no loose mounting bolt.	See 5-1.
	Check that there is no loose connector.	Retighten it.
	Visually check that cams all move smoothly.	Visual
Quarterly inspection	Check that there is no rattling at chuck/unchuck sensor sections.	Tactile
	Check that there is no rattling in the pivot pins, lock pins and the housing.	Tactile
Biannual inspection	Check that no excessive wear is observed on the mating surfaces of cams, tapered pins, bush, robot adaptor and tool adaptor	Visual
Annual inspection	Pull out the spring-pin contact and clean it with alcohol or the like.	See 7-3-2.
	Replace the O-rings on the robot side pneumatic ports.	See 7-3-3.
4-year inspection	Overhaul Disassembly, cleaning, parts replacement and re-assembly	Please contact us.

7-3. Maintenance Procedures

This section describes maintenance and inspection procedures for daily inspections that can be performed with robot/tool adaptors attached to the robot and hand.

7-3-1. ATC Grease Up

Pressure-, heat-, and water-resistant mineral lithium composite grease or lithium grease should be applied thinly and evenly to external sliding faces.

For new products, please check that grease has been already applied in plant. Application points are indicated in Fig. 12. (Recommended grease: SUMIPLEX BN NO. 1 (manufactured by Sumico Lubricant))

⚠ CAUTION

Do not use molybdenum grease.

As Nitta uses mineral lithium composite grease, be sure to use the same type of grease. Recommended NLGI No. (JIS consistency number) is No.1 and No.2.

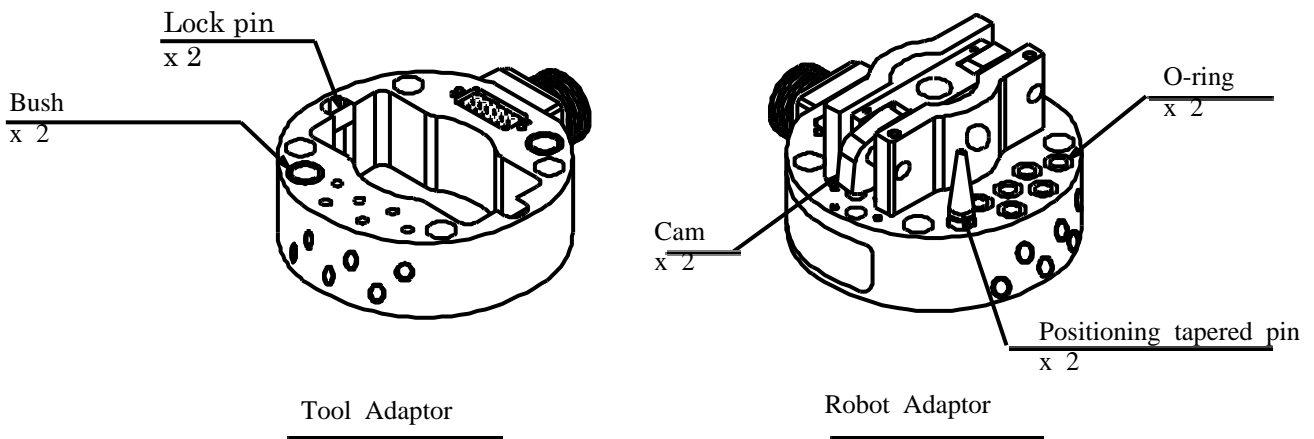

Fig. 12. ATC grease-up points

⚠ CAUTION

Without greasing, prying and early wear will be generated on each part.

7-3-2. Tool Side Electric Contact Pin Replacement

Pull out the pin tip part straight upward. Then the tip part and external brass cylinder embracing it will be removed.

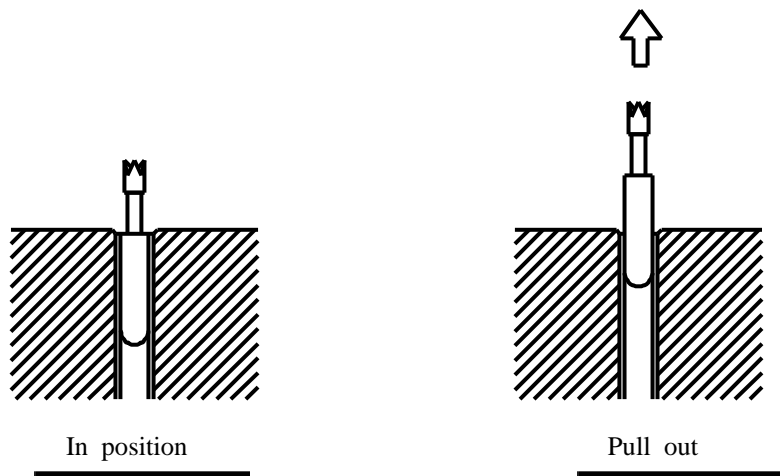

Fig. 13. Tool side spring pin replacement

This task can be performed by hand with no tool, but longnose pliers will make it easier. After removing any damaged pin as described above, press in a new pin until the brass section of its external cylinder gets into the module. The replacement procedure is now completed. Check that the pin's height is the same as other pins' and gently press the pin tip to check that it smoothly moves.

If the pin is broken:

Use a sharp file (second-cut) of $\phi 2-3\text{mm}$ to pull out the pin.

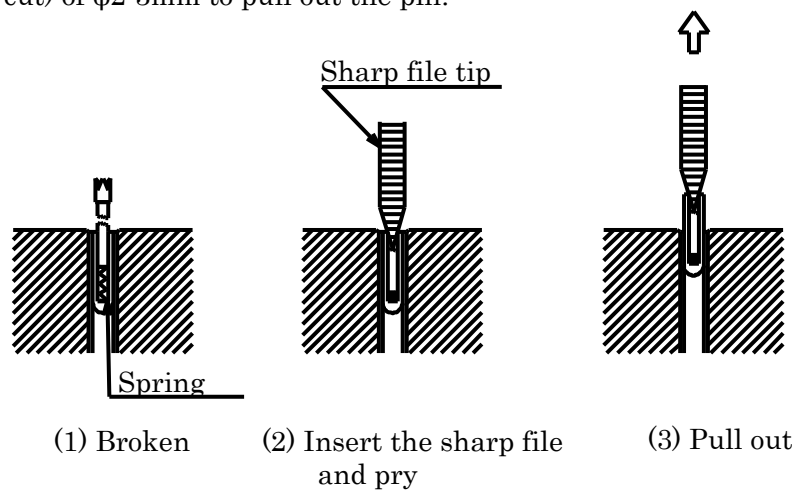

Fig. 14. Pulling out a broken pin

7-3-3. Replacement of Robot Side Pneumatic Port O-ring

As illustrated in Fig. 15, O-rings are fitted onto the robot side adaptor connection surface. If there is any visible damage of or air leakage from any O-ring, replace with a new one. Use a race knife or the like to remove an O-ring.

At this point, be careful not to scratch the housing.

Grease up a new O-ring (SUMIPLEX BN NO.1 (manufactured by Sumico Lubricant) or equivalent grease) before fitting it to the housing. At this point, ensure that the O-ring is not twisted or hooked.

If O-rings break frequently, robot side port damage, wearing of tapered pins or bush, or improper teaching should be suspected.

(For teaching, refer to 6-4.)

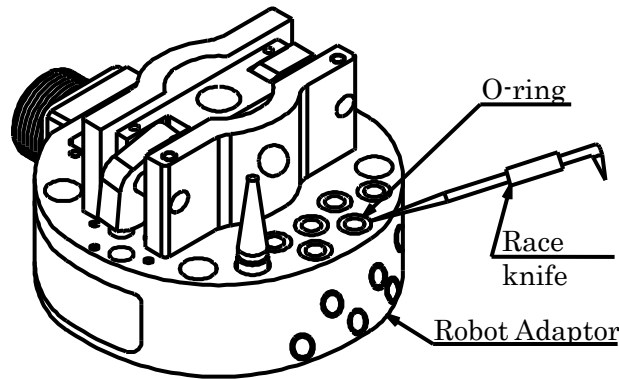

Fig. 15. O-ring replacement

7-3-4. Chuck/Unchuck Sensor Conduction Check

Apply voltage to the chuck/unchuck sensor via a sequencer or the like and check that the LED is turned ON. For connection, please refer to the internal wiring chart.

Chart 5. Chuck/unchuck sensor conduction check table

	Chuck end	Unchuck end	Coupling check end
ATC separated (unchuck)	OFF	ON	OFF
ATC connected (unchuck)	OFF	ON	ON
ATC connected (chuck)	ON	OFF	ON

7-3-5. Tapered Pin Replacement

The tapered pin is fixed to the robot adaptor with a screw. For disassembly, remove the tapered pin mounting bolt from back of the robot adaptor and knock out the pin by using a punch or the like. For assembly, apply Locktite 242 (medium strength) into tapered pin thread and then tighten the mounting bolt. At this point, check that the tapered pin's protrusion length is 37mm.

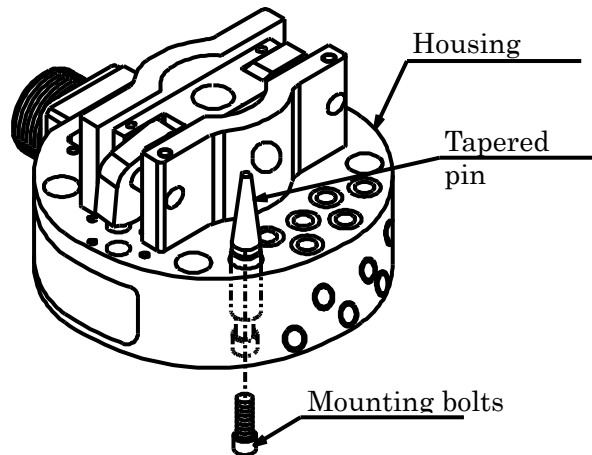

Fig. 16. Tapered pin replacement

7-3-6. Bush Replacement

The bush is inserted into the tool adaptor.

For replacement, knock it out from the tool adaptor coupling surface to the back side (plate side).

For attachment, be careful not to allow the bush end plane to protrude from the tool adaptor's back surface.

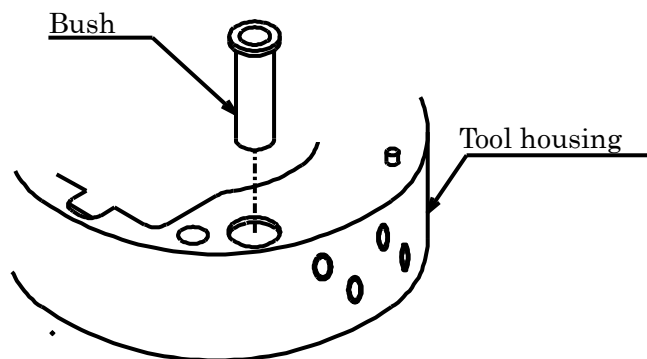

Fig. 17. Bush replacement

7-3-7. Tool Adaptor Lock Pin Replacement

The lock pin is fixed by light transition fitting. For replacement, loosen the set screw and insert a punch into the hole to knock it out. For attachment, insert the lock pin while adjusting the lock pin hole. Then lightly apply Locktite 222 (low strength) to the set screw (bar tip) and tighten it.

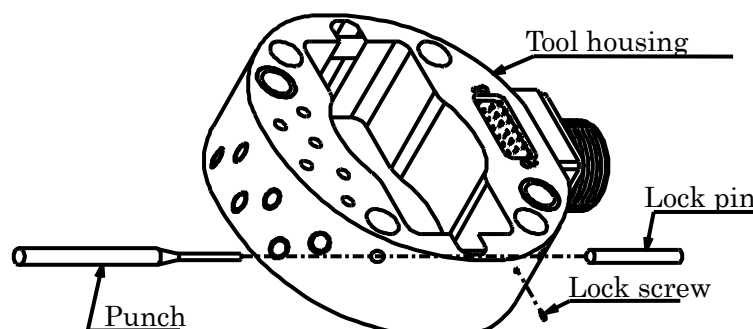

Fig. 18. Lock pin replacement

8. Recommended Spare Parts

ATC parts that should be prepared as spare parts are listed according to the ranks specified below. To purchase these parts, check the manufacture No. (serial No.) and contact us.

Rank A: Consumables and items whose expected replacement interval is relatively short

Rank B: Mechanical parts that work frequently

Rank C: Important mechanical parts

Chart 6. Recommended spare parts

Rank	Name	Qty.	Material	Part No.
A	O-ring (robot side)	6	NBR	P-5 (Class 1 A)
A	Electric signal pin (tool side)	15		GCSP2M333
C	Tapered pin (robot side)	2	Steel	EBR-004-01
C	Pivot pin (robot side)	2	Steel	EBR-00B-00
C	Bush (tool side)	2	Steel	EBT-002-01
C	Lock pin (tool side)	2	Steel	EBT-003-00

For part codes of ATC components, please refer to the "internal parts placement diagram."

Precautions for replacement

If you find any damage to the ATC when replacing with spare parts, please contact us.

Do not re-calibrate or disassemble the proximity (lead) SW when replacing with spare parts.

(The chuck/unchuck sensor is calibrated appropriately before shipment. Displacement may cause malfunction of the sensor.)

9. Backup Item

When a prolonged downtime for inspection and correction is expected due to robot interference or exposure to water and our standard adaptor plate (or equivalent) is used, the ATC can be removed from the adaptor plate and simply replaced with backup equipment with reproducibility of $\pm 0.5\text{mm}$, unless it is used for any special application.

Also, Nitta equipment is composed of the ATC and optional modules, so the ATC can be replaced along with adaptors and modules (except for special modules).

In case of short line takt or parts prone to be damaged due to strenuous operations, it is recommended to prepare aforementioned spare parts along with backup equipment in order to minimize line downtime.

10. Troubleshooting

10-1. Cause Effect Diagram

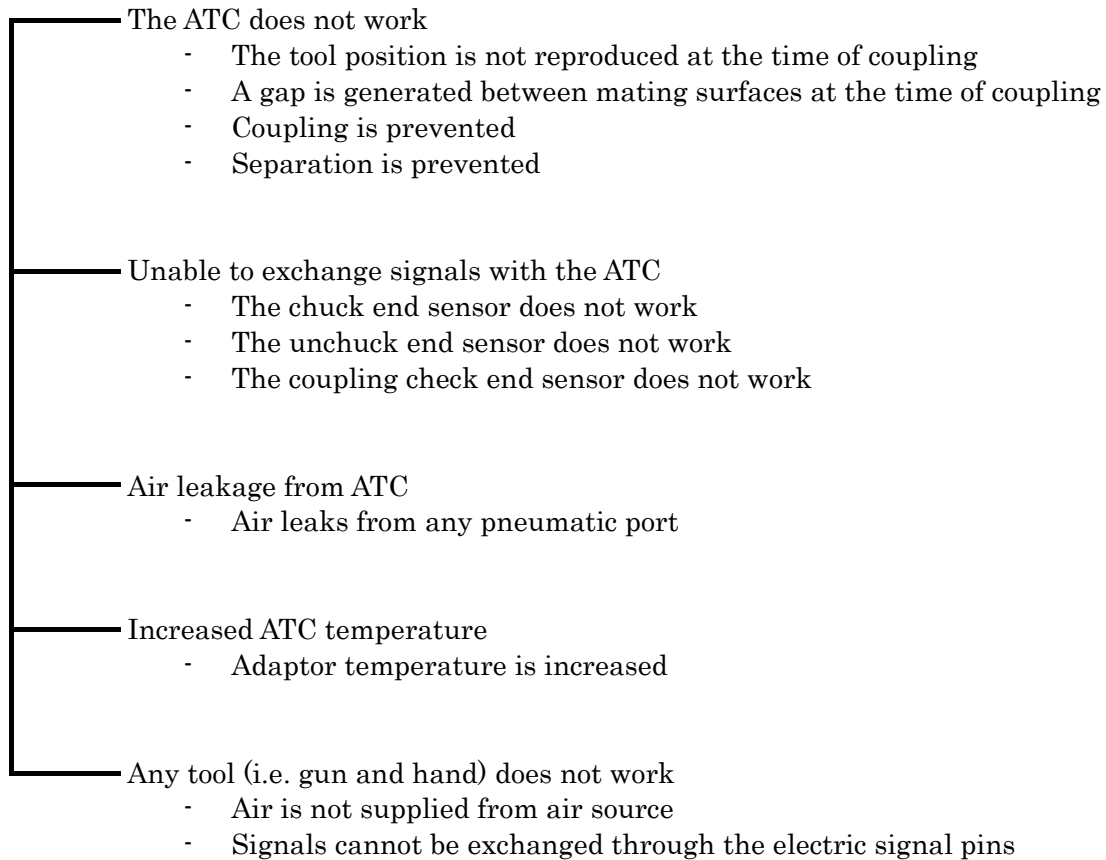

10-2. Trouble Symptoms and Response Actions

10-2-1. ATC Does Not Work

The tool position is not reproduced at the time of coupling

- 1) Check if there is a gap between the robot adaptor and the tool adaptor : Correct teaching
- 2) Check if there is excessive wear or damage of the tapered pin : Replace the tapered pin (See7-3-5.)
- 3) Check if there is excessive wear or damage of the bush : Replace the bush (See7-3-6.)
- 4) Check if there is any loose mounting bolt : Retighten it (See 5.)
- 5) Check if there is any excessive load that may deform any ATC section : Please contact us
- 6) Check if the load exceeds the rated load : Please contact us

A gap is generated between mating surfaces at the time of coupling

- 1) Check if an appropriate gap is maintained at the time of coupling : Perform coupling at a position where the coupling check end sensor is ON
- 2) Check if there is any foreign substance on the coupling surface : Remove it
- 3) Check if there is any excessive load that may deform any ATC section : Please contact us
- 4) Check if any molybdenum grease is used : Stop using it immediately and use SUMIPLEX BN NO.1 (manufactured by Sumico Lubricant) or equivalent grease

Coupling is prevented

- | | |
|---|--|
| 1) Check that air pressure is applied | : Apply air pressure of 0.4-0.6MPa |
| 2) Check if the solenoid valve works | : Check |
| 3) Check if the robot adaptor and the tool adaptor are too far from each other | : Keep pressing it until the coupling check proximity sensor is in |
| 4) Check if there is any foreign substance in the cam driving section that may inhibit its action | : Remove it |
| 5) Check for any air leakage from the cylinder | : Please contact us |
| 6) Check if the cylinder is damaged | : Please contact us |
| 7) Check if any excessive load that may cause deformation is applied to the cam section | : Please contact us |
| 8) Check if the tool stand is deflected | : Reinforce |
| 9) Check if the tool stand anchor bolt is loose | : Retighten it |

Separation is prevented

- | | |
|---|---|
| 1) Check if air pressure is applied | : Apply air pressure of 0.4-0.6MPa |
| 2) Check if the solenoid valve works | : Check |
| 3) Check if any excessive offset load is applied to the tool adaptor | : Keep pressing it against the tool stand until the coupling check end sensor is in |
| 4) Check if you have applied any interlock | : Check the circuit |
| 5) Check if there is any foreign substance in the cam driving section that may inhibit its action | : Remove it |
| 6) Check if any excessive load that may cause deformation is applied to the cam driving section | : Please contact us |
| 7) Check if the cam surface is greased up | : Damage may be caused by prying without lubrication. Grease up the cam surface. |
| 8) Check if pressing force required for separation is applied to the ATC | : Check |
| 9) Check if the tool stand is deflected | : Reinforce |
| 10) Check if the tool stand anchor bolt is loose | : Retighten it |

10-2-2. Unable to Exchange Signals with ATC

The chuck end sensor does not work

- | | |
|---|--|
| 1) Check if there is any rattling with the part | : Retighten the mounting plate |
| 2) Check for any leakage current from the interlock board | : Ensure that leakage current is below 1.3mA |
| 3) Check if any metal object is attached on the sensor surface | : Remove |
| 4) Check if both of the two cams move to the coupling position (preventing normal coupling) | : Check from a hole for manual separation (See 6-5-1.) |
| 5) Check if there is a gap between the robot adaptor and the tool adaptor | : Perform coupling at a position where the coupling check proximity sensor is ON |
| 6) Check if the cable is connected | : Check |
| 7) Check if the cable is damaged or disconnected | : Check |
| 8) Check if the interlock board works normally | : Check the circuit |
| 9) Check if the sensor is damaged or malfunctioning | : Please contact us |
| 10) Check for any water exposure (internal short-circuit) | : Please contact us |

The unchuck end sensor does not work

- 1) Check if there is any rattling with the part : Retighten the mounting plate
- 2) Check for any leakage current from the interlock board : Ensure that leakage current is below 1.3mA
- 3) Check if any metal object is attached on the sensor surface : Remove
- 4) Check if the cams on both sides move to the separating position (preventing normal separation) : Check from a hole for manual separation (See 6-5-1.)
- 5) Check if the cable is connected : Check
- 6) Check if the cable is damaged or disconnected : Check
- 7) Check if the interlock board works normally : Check the circuit
- 8) Check if the lead switch is damaged or malfunctioning : Please contact us
- 9) Check for any water exposure (internal short-circuit) : Please contact us

The coupling check end sensor does not work

- 1) Check if there is any rattling with the part : Retighten the mounting plate
- 2) Check for any leakage current from the interlock board : Ensure that leakage current is below 1.3mA
- 3) Check if any metal object is attached on the sensor surface : Remove
- 4) Check if there is a gap larger than 0.5mm between the robot adaptor and the tool adaptor : Correct teaching
- 5) Check if the cable is connected : Check
- 6) Check if the cable is damaged or disconnected : Check
- 7) Check if the interlock board works normally : Check the circuit
- 8) Check if the proximity sensor is damaged or malfunctioning : Please contact us
- 9) Check for any water exposure (internal short-circuit) : Please contact us

10-2-3. Air Leakage from ATC

Air leaks from any pneumatic port

- 1) Check if any robot adaptor O-ring is damaged : Replace the O-ring (See7-3-3.)
- 2) Check if the one-touch joint for air is securely screwed in : Check
- 3) Check if the tube is securely inserted : Check
- 4) Check if there is a gap between coupling surfaces of the robot adaptor and the tool adaptor at the time of coupling : Perform coupling securely (The coupling check end sensor should be ON)

10-2-4. Increased ATC Temperature

Adaptor temperature is increased

- 1) Check for any heated section during in the work environment : Keep it away from the heated section as long as possible
- 2) Check if the electric capacity of the spring pin for signal is exceeded : Observe the electric capacity limit

10-2-5. Tool (i.e. Gun and Hand) Does Not Work

Air is not supplied from air source

- | | |
|--|--|
| 1) Check if air pressure is applied | : Apply air pressure below 0.855MPa |
| 2) Check if the solenoid valve works | : Check |
| 3) Check if the robot adaptor and the tool adaptor are securely coupled | : Perform coupling securely (The coupling check end sensor should be ON) |
| 4) Check for any excessive bending or twisting of the tube | : Check |
| 5) Check if any robot adaptor O-ring is damaged | : Replace the O-ring |
| 6) Check if the same port number is used by the robot adaptor and the tool adaptor | : Check |
| 7) Check if the tool is damaged | : Check |

Signals cannot be exchanged through the electric signal pins

- | | |
|---|--|
| 1) Check if any signal is transmitted to the electric signal pin | : Check by using a tester, etc. |
| 2) Check if the tool is damaged | : Check |
| 3) Check for any excessive bending or twisting of the signal cable | : Check |
| 4) Check if the connector is securely connected | : Securely connect it |
| 5) Check if the robot adaptor and the tool adaptor are securely coupled | : Perform coupling securely (The coupling check end sensor should be ON) |
| 6) Check for any damage on the electric signal pin module | : Please contact us |
| 7) Check for any damage of or foreign substance trapped in the electric pin section of the electric signal pin module | : Replace the electric signal pin (See7-3-2.) |
| 8) Check for any dent or involvement in the electric pin section of the electric signal pin module | : Please contact us (Visually check if the pin heights are uniform) |
| 9) Press the electric pin section of the electric signal pin module by finger and check if it moves smoothly | : Replace the electric signal pin (See7-3-2.) |

