

# INSTRUCTION MANUAL

## Automatic Tool Changer NITTAOMEGA XC400

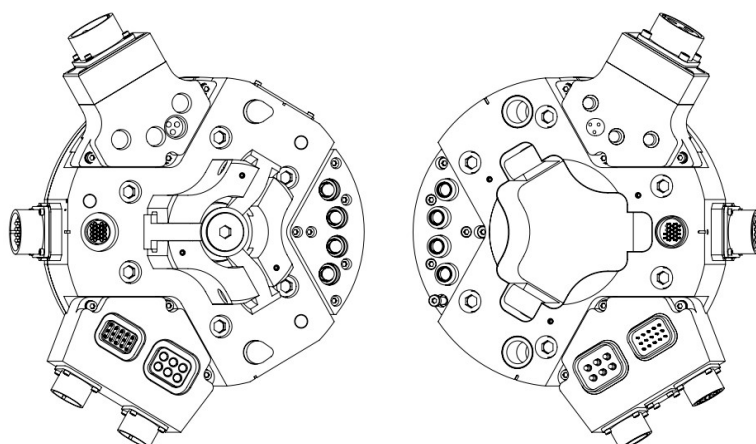

### NOTICE

**For use of this document:**

Please keep this document always readily available to those who use the product. If you need an additional copy, please download the document from our website:

<https://www.nitta.co.jp/en>

## Nitta Corporation

Osaka HQ: 4-4-26 Sakuragawa, Naniwa-ku, Osaka, Osaka 556-0022

Tel: +81 6-6563-1271

FAX: +81 6-6563-1272

Tokyo Branch: 8-2-1 Ginza, Chuo-Ku, Tokyo 104-0061

Tel: +81-3-6744-27025

FAX: +81-3-6744-2707

Nagoya Branch: 1-17-23 Meieki-Minami, Nakamura-ku, Nagoya 450-0003

Tel: +81-52-589-1321

FAX: +81-52-566-2005

Nabari Plant: 1300-45 Yabata, Nabari, Mie 518-0494

Tel: +81-595-64-2916

FAX: +81 595-63-9527

Renewed: September 2013

Revised: December 2018

Ver. No.:rev3

# Contents

Preface .....	I
Notice .....	I
Product Warranty .....	I
Unpacking and Check.....	I
Safety Precautions .....	II
<b>1. Overview of the Automatic Tool Changer (ATC) .....</b>	<b>1</b>
<b>1-1. Robot Side .....</b>	<b>1</b>
<b>1-1-1. Robot Adaptor .....</b>	<b>1</b>
<b>1-1-2. Selection of Input Device .....</b>	<b>2</b>
<b>1-1-3. Robot Adaptor Plate (Optional) .....</b>	<b>2</b>
<b>1-2. Tool Side .....</b>	<b>3</b>
<b>1-2-1. Tool Adaptor .....</b>	<b>3</b>
<b>1-2-2. Tool Adaptor Plate (Optional) .....</b>	<b>3</b>
<b>1-3. Option.....</b>	<b>3</b>
<b>2. Configuration:.....</b>	<b>3</b>
<b>3. Standard Specifications .....</b>	<b>4</b>
<b>3-1. Common Specifications.....</b>	<b>4</b>
<b>3-2. ATC Specifications .....</b>	<b>5</b>
<b>3-2-1. ATC Specifications.....</b>	<b>5</b>
<b>3-2-2. Internal Power Wire for ATC .....</b>	<b>6</b>
<b>3-2-3. Coupling Check End Sensor.....</b>	<b>6</b>
<b>3-2-4. Chuck and Unchuck Sensor .....</b>	<b>7</b>
<b>3-2-5. LED ASSY Specifications.....</b>	<b>7</b>
<b>3-3. Spot Welding Module Specifications (Seal Connector Specifications).....</b>	<b>8</b>
<b>3-3-1. Spot Welding Module Specifications.....</b>	<b>8</b>
<b>3-3-2. Internal Power Wire for Spot Welding Module (Power) .....</b>	<b>9</b>
<b>3-3-3. Internal Power Wire for Spot Welding Module (Earth).....</b>	<b>9</b>
<b>3-4. Spot Welding Module Specifications (Seal Connector Specifications).....</b>	<b>10</b>
<b>3-4-1. Spot Welding Module Specifications.....</b>	<b>10</b>
<b>3-5. Servo Motor Module Specifications .....</b>	<b>11</b>
<b>3-5-1. Servo Motor Module Specifications.....</b>	<b>11</b>
<b>3-5-2. Internal Power Wire for Servo Motor Module .....</b>	<b>12</b>
<b>3-6. Hydraulic Module Specifications (Rc3/8 Specifications).....</b>	<b>13</b>
<b>3-7. Hydraulic Module Specifications (Rc1/2 Specifications).....</b>	<b>14</b>

---

3-8. Pneumatic Module Specifications (Rc1/4 Specifications) .....	15
3-9. Pneumatic Module Specifications (Rc1/2 Specifications) .....	16
3-10. Signal Module Specifications .....	17
3-10-1. Signal Module Specifications .....	17
3-10-2. Internal Power Wire for Signal Module .....	18
3-11. Fall Protection System Specifications .....	19
3-12. Precautions for Allowable Load and Installation .....	20
3-13. Allowable Electric Load.....	20
<b>4. Part Names .....</b>	<b>21</b>
<b>5. Procedures of Installation to Robot/Tool.....</b>	<b>22</b>
<b>5-1. Robot Adaptor .....</b>	<b>22</b>
<b>5-2. Tool Adaptor .....</b>	<b>22</b>
<b>5-3. Connecting to Fitting/Removal Port .....</b>	<b>24</b>
<b>5-4. Electric Wiring.....</b>	<b>25</b>
<b>5-5. Cable Fixing.....</b>	<b>25</b>
<b>5-6. Precautions for Installing ATC to a Tool.....</b>	<b>26</b>
<b>5-6-1. ATC Orientation .....</b>	<b>26</b>
<b>5-6-2. ATC Grease Up.....</b>	<b>27</b>
<b>5-6-3. Proximity of ATC .....</b>	<b>27</b>
<b>5-6-4. Precautions for using a servo motor for a tool .....</b>	<b>27</b>
<b>5-7. Torque Level for Modules.....</b>	<b>28</b>
5-7-1. Wiring for Spot Welding Module (Seal Connector Specifications) .....	29
<b>5-7-1. When a Hydraulic/Pneumatic Module Is Used:.....</b>	<b>32</b>
<b>5-7-2. When a Spot Welding/Signal Module Is Used:.....</b>	<b>32</b>
<b>6. Operations and Programming .....</b>	<b>33</b>
<b>6-1. Checking before Teaching (Robot Operations) .....</b>	<b>33</b>
<b>6-2. Operations and Programming.....</b>	<b>34</b>
<b>6-3. Basic Flow of ATC .....</b>	<b>35</b>
<b>6-4. Interlocking around ATC.....</b>	<b>36</b>
<b>6-5. Precautions for Operations .....</b>	<b>37</b>
<b>6-6. Points to Check during Line Downtime (or Line Uptime).....</b>	<b>39</b>

**6-7. Emergency Response Actions** ..... 40

**6-7-1. Manual Unchuck in Case of Emergency** ..... 40

**6-7-2. Response Actions to Interference or Crash** ..... 41

**6-7-3. Response Action to Water Exposure** ..... 41

**6-7-4. Precautions for Transportation**..... 42

---

## Preface

Thank you for choosing Nitta Automatic Tool Changer (hereafter referred to as "ATC").

This instruction manual provides precautions for handling, detailed descriptions of the specifications and mandate inspection and maintenance items for secure applications and appropriate maintenance and inspection of the system, focusing on mechanical sections of ATC. Therefore, those in charge of introduction line planning, maintenance and inspection, unpacking or actual operations of the product must read this document and fully understand the ATC before use.

Please keep this document always readily available to those who use the product.

- All rights reserved.
- External appearance and specifications described in this document are subject to change for improvement.
- Be sure to read this document carefully before working on the product.
- Be sure to confirm whether workers are required to be sufficiently trained for applicable expertise.
- Take note that we assume no responsibility regarding any damage or accident that occurs in works performed by customers.

## Notice

This document is only intended for customers of Nitta Corporation (hereinafter referred to as "the company"). Technical information and drawings presented in this document are the proprietary of the company and it is prohibited to publish them to any third party without prior written consent of the company. The contents of this document are subject to change without any prior notice. The delivered product may not be the same as figures and photos contained herein due to any later change in specifications.

## Product Warranty

- Warranty period  
1 year from the delivery date of this product or 3,000 hours of operation, whichever comes first.
- Warranty subject  
Any genuine part of the product exhibiting defect in material or manufacturing will be fixed or serviced without charge within the warranty period.
- Exclusion  
Items listed below are excluded from warranty:
  - (1) Any failure and accident arising out of user's negligence
  - (2) Consumables
  - (3) Any failure caused by natural disaster, accident, fire, theft or unauthorized use, etc.
  - (4) Any failure or accident arising out of non-conformity to maintenance and inspection instructions set forth in this document
  - (5) Any failure or accident arising out of repair, adjustment, or alteration performed by other than Nitta engineers
  - (6) Any failure caused by any use of used parts

Any secondary damage such as line stoppage due to a system failure or damage arising out thereof is also out of the warranty coverage.

## Unpacking and Check

Although we exercise thorough care to eliminate wrong delivery before shipment, please check the following items when you unpack the product for confirmation. Should there be any defect or missing item, please contact our office indicated in the cover page of this document.





- Please check that mounting bolts are included. (See the relevant delivery specifications.)
- Please check the spare parts. (To be determined in separate meetings.)
- For details of options, e.g. special modules, please feel free to contact us.

For Safe Use of the Product

a) Hazard, warning and cautions indications in this document

This section describes safety precautions for proper use of the Nitta product and prevention of injuries and property damages. These precautions are classified into three levels according to severity of potential hazards and damages that may be caused by non-conformity thereto.

**Indications in this document**

 <b>DANGER</b>	Improper use disregarding this indication may lead to a hazardous situation which may result in death or serious injury and requires urgent alerting when such hazard is materialized.
 <b>WARNING</b>	Improper use disregarding this indication may lead to a hazardous situation which may result in death or serious injury.
 <b>CAUTION</b>	Improper use disregarding this indication may lead to a hazardous situation which may result in minor injury or property damage.
 <b>Referenc</b>	This indicates use examples, etc.
 <b>MEMO</b>	This indicates special instructions less important than cautions.

Please note that a severe accident may occur depending on situations even when instructions in the indications are observed. Please strictly observe the instructions.

<div style="border: 2px solid blue; padding: 10px; width: fit-content; margin: auto;">Disclaimer</div>	<p>(1) We assume no responsibilities for any damage arising out of any failure caused by intention or negligence of customer (including software malfunction), or any reason not attributable to Nitta, such as an accident or natural disaster.</p> <p>(2) We assume no responsibilities for any damage caused by any use not described or prescribed in our catalogs (including the instruction manual).</p> <p>(3) We assume no responsibilities for any failure alleged to be warrantable by customers if there is no clear evidence of our responsibility.</p> <p>(4) We assume no responsibilities for any incidental damage arising out of use of or inability to use our product (including but not limited to loss of business profit and business interruption).</p>
--	--

b) Introduction

ATC does not work alone and is only usable when being equipped on a robot and a compatible unit. For increased safety of the entire system, it is necessary to consider not only the single ATC but also the robot system and compatible unit system as a whole.

 **DANGER**

---

For use of ATC, be sure to observe safety instructions concerning core robots and compatible units. For any work within the robot safety fence, consider preparing a safety system design to shut down power over 50V once any person gets into the fenced area.

---

---

c) General Precautions

---

 **CAUTION** Personnel engaged in installation, programming and maintenance works inside the robot safety fence for the ATC must have expertise in robot operations (having completed expert training). In addition, those engaged in disassembly or assembly works of the ATC, whether in or out of the safety fences, shall read this document, installation guide, and maintenance procedures.

---

 **WARNING** In addition, for works in the safety fence area, be sure to wear appropriate clothing for the work with personal protective equipment such as a hard hat, safety boots, etc. For internal disassembly works for the ATC, use protective glasses for protection against pop-out parts.

---

 **WARNING** Do not use this product in any of the environments listed below. Otherwise, operators may be injured.

- Flammable environment (containing highly volatile and flammable substances)
- Environment with explosive atmosphere (e.g. combustible gas and chemical spattering)
- Environment exposed to water/water drops or highly humid environment
- Environment with corrosive atmosphere
- Environment with high degree of radiation

When the product is used under any of the above environment, we assume no responsibility for any failure or damage.

Also, malfunction may occur in an environment with spattering dust, chip and cutting oil, etc.

---

d) Precautions for Installation

---

 **WARNING** For installation of the ATC, remove the pertinent product and place it out of the robot safety fence as long as possible so that installation can be performed securely.

---







 **DANGER** If installation work is performed inside the safety fence, securely shut off the power over 50V from the ATC and ensure that the robot is securely stopped before entering into the fence area.

---



 **DANGER** Be sure to check the following items before starting the installation procedure:

- (a) Welding power source, control power source and driving power source are all shut off before work.
- (b) All hydraulic and pneumatic pressure sources are off before work.
- (c) All residual hydraulic and pneumatic pressure is released before work.
- (d) Note that some connectors and cables may be hot depending on their specifications.

---

 <b>DANGER</b>	Turning the power supply or hydraulic/pneumatic pressure source ON during the installation work without notifying the operator(s) may create an extremely dangerous situation. Establish a procedure to always prevent such events for safety in work areas.
 <b>CAUTION</b>	Be sure to install specified parts. In addition, when you replace parts, install parts to their original positions and be sure to perform inspections in accordance with certain procedures.
 <b>WARNING</b>	Ensure that the rated load (moment torque) does not exceed product's rated value. Otherwise, not only the product functionality and life may be adversely affected but also unexpected accident may occur.
 <b>WARNING</b>	Ensure that the electric load applied to the signal pin and electrode does not exceed the rated voltage and allowable current. Otherwise, not only the product functionality and life may be adversely affected but also unexpected accident may occur.
 <b>WARNING</b>	Supply water and air to hydraulic/pneumatic and ATC chuck/unchuck ports so as to maintain pressure within the rated range. Otherwise, not only the product functionality and life may be adversely affected but also unexpected accident may occur.
 <b>MEMO</b>	<ul style="list-style-type: none"> <li>- To install a robot adaptor, set the robot mounting surface facing up, rather than horizontal. Then robot adaptor installation becomes relatively safer.</li> <li>- When installing a tool adaptor, set tools on the tool stand. Then tool adaptor installation becomes relatively safer.</li> </ul>
 <b>WARNING</b>	Switch air supply to a chuck/unchuck port in the detached state to check that the coupling cam motions are correct. Operating without doing this may cause tool falling, product damage, or unexpected accident.
 <b>DANGER</b>	When manually switching air supply of the chuck/unchuck port, set tools on the tool stand. Otherwise, improper motions or piping may cause tool falling, product damage, or unexpected accident.
 <b>CAUTION</b>	Arrange cables and tubes without causing catching during robot motions. Otherwise, the ATC and its modules may be damaged.

e) Precautions for teaching

 <b>WARNING</b>	With the tool detached, check that the interlock signals output from the ATC are correct. Operating without doing this may cause tool falling, product damage, or unexpected accident.
 <b>WARNING</b>	For chuck/unchuck, switch air supply for chuck/unchuck with the coupling planes of robot side and tool side adaptors are horizontally coherent on the tool stand. Otherwise, an unexpected accident may occur due to tool falling, in addition to damage to the ATC and its functional modules due to prying.



---

 **DANGER**

When the welding power is on, there is a risk of electricity leakage. Do not touch any component connected with the ATC.

---

f) Precautions for Long-Term Shutdown or Transportation

---

 **DANGER**

The failsafe mechanism serves to prevent falling. Do not continue using the product when the air pressure is decreased. Otherwise, the gap between contact surfaces of robot and tool adaptor is increased and unexpected accident may occur.

When the tool is left coupled by the failsafe mechanism only for a prolonged period of time, the gap between contact surfaces of robot and tool adaptor is increased by vibration, etc. and unexpected accident such as falling may occur.

If it is absolutely necessary to stop the air supply for a long time with the tool coupled, be sure to take measures against falling, e.g. fixing it by rope, etc.

---

# 1. Overview of the Automatic Tool Changer (ATC)

A pneumatic-driven system is employed for the Nitta ATC. Basically, the ATC consists of 2 components: a robot adaptor and a tool adaptor. The ATC is compatible with all the robot tools with respective adaptor plates (optional). In addition, the ATC and its functional modules are equipped with transmission mechanisms such as a signal pin to transmit signals and power source to the tool, and pneumatic port.

## [ Transmission Mechanism ]

The ATC have electric signal pins to transmit/receive signals between the robot and tool. For the number of pins, refer to the drawing.

### 1-1. Robot Side

#### 1-1-1. 1-1-1. Robot Adaptor

The robot adaptor is a basic component of the ATC. Each robot adaptor is equipped with sensors that transmit signals (chuck end signal, unchuck end signal and coupling check end signal) to communicate its attachment conditions.

## [ Chuck/Unchuck Mechanism ]

The cam mechanism to connect a robot adaptor and tool adaptor together is of a special structure, which is designed to automatically compensate for misalignment at the time of jointing and wear allowance to be generated over time. These cams are operated by an air cylinder and designed not to come off under temporary loading above the rated load.

Under such load, the contact surfaces of the robot adaptor and the tool adaptor will be slightly separated, but the adaptors will never be completely separated. Also, these cams are driven by a spring-return pneumatic cylinder, as a fail-safe mechanism to prevent falling of the tool adaptor even in the event of sharp reduction of the air pressure.



### **DANGER**

The failsafe mechanism serves to prevent falling. Do not continue using the product when the air pressure is decreased. Otherwise, the gap between contact surfaces of robot and tool adaptor is increased and unexpected accident may occur.

When the tool is left coupled by the failsafe mechanism only for a prolonged period of time, the gap between contact surfaces of robot and tool adaptor is increased by vibration, etc. and unexpected accident such as falling may occur.

If it is absolutely necessary to stop the air supply for a long time with the tool coupled, be sure to take measures against falling, e.g. fixing it by rope, etc.

## [ Chuck/Unchuck Sensor Signals ]

Chuck end signal (coupling end)

Signal that indicates the cam is not fully engaged. When this signal and a coupling check signal are both active, the robot can pick the tool adaptor from the tool stand.

Unchuck end signal (detachment end)

This signal indicates that a cam to lock (couple) the robot adaptor and tool adaptor is drawn into the robot adaptor. While this signal is active, the robot adaptor may approach the tool adaptor freely and leave the tool adaptor after completion of tool replacement on the tool stand safely.

Coupling check end signal (face end)

This signal indicates that jointing planes of both the robot adaptor and tool adaptor are in contact. This signal indicates that both adaptors are in parallel and their contact surfaces are sufficiently close to each other, and that the cam is positioned appropriately to move for the chuck/unchuck operation with no problem.

## 1-1-2. Selection of Input Device



### CAUTION

Check specifications of the input device. Signals representing the robot adaptor attachment condition may not be present.

The chuck/unchuck sensor signal output circuit of the unit consists of a photo coupler operated by turning the proximity sensor ON/OFF, and serial resistor for photo coupler protection. Therefore, the residual voltage of the signal output circuit varies depending on the input current of the selected input device. For input device selection, check the input current of the device and ON determination voltage and select an input device with which ON determination is possible.

Ex: When input current value is 6 (mA)

- When chuck or unchuck is ON

$$\text{Residual voltage } V1 = 680 (\Omega) \times 6 (\text{mA}) + 0.9 + 0.8 = 5.78 (\text{V})$$

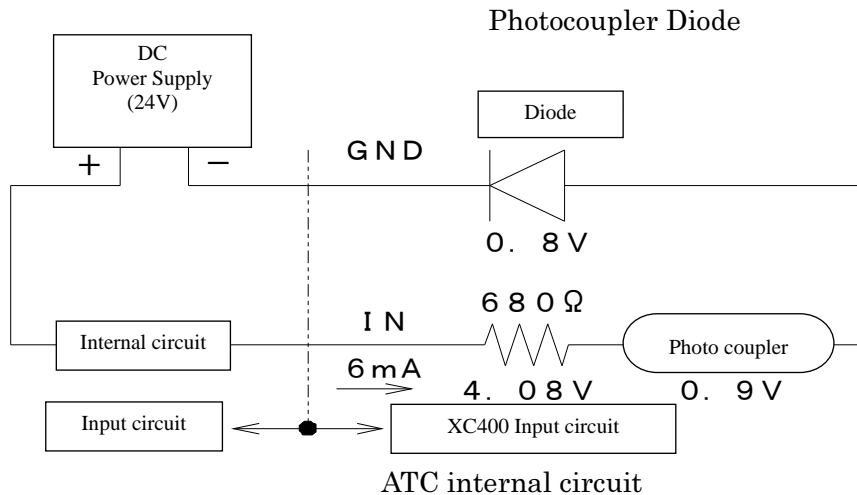

- When the coupling check end is ON

$$\text{Residual voltage } V2 = 680 (\Omega) \times 6 (\text{mA}) + 2.7 + 0.8 = 7.58 (\text{V})$$

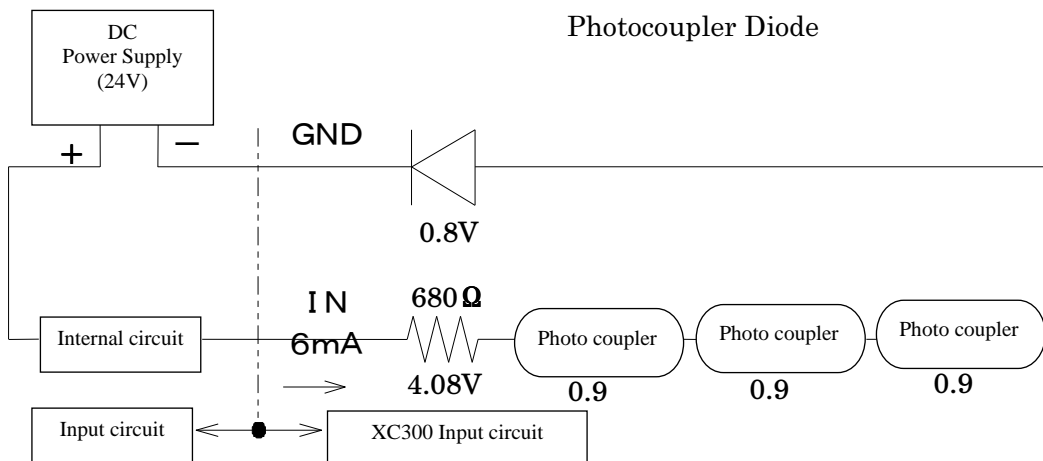

Therefore, select an input device with which ON determination is possible with 8 (V) or higher voltage relative to 0V common.

## 1-1-3. 1-1-3. Robot Adaptor Plate (Optional)

A robot adaptor plate is to be used to attach a robot adaptor to a robot used. No processing of holes and screws for installation to a robot is performed on standard products. (We may perform such processing upon your request. You may also prepare a robot adaptor place on your own. For precautions for installation of an adaptor plate onto the robot adaptor unit, refer to 5. Procedures of Installation to Robot/Tool in this document.

## 1-2. Tool Side

### 1-2-1. 1-2-1. Tool Adaptor

A tool adaptor is another fundamental component of the ATC, to which a tool is attached. A tool adaptor is equipped with lock pins to be engaged with robot adaptor's locking cams.

### 1-2-2. 1-2-2. Tool Adaptor Plate (Optional)

A tool adaptor plate is to be used to attach a tool adaptor to a tool used.

No processing of holes and screws for tool attachment is performed on standard products. (As with the robot adaptor plate, we can offer a mounting hole drilling service following your instructions. You may also prepare an adaptor plate on your own. For precautions for installation of an adaptor plate onto the tool adaptor unit, refer to 5. Procedures of Installation to Robot/Tool in this document.

## 1-3. Option

For details of options, e.g. non-standard signal pin modules, spot welding modules, and pneumatic modules, please feel free to contact us.

## 2. Configuration:

This system is composed of the ATC and additional functional modules assembled thereto. The signal pin ASSY is a spring-type electric contact.

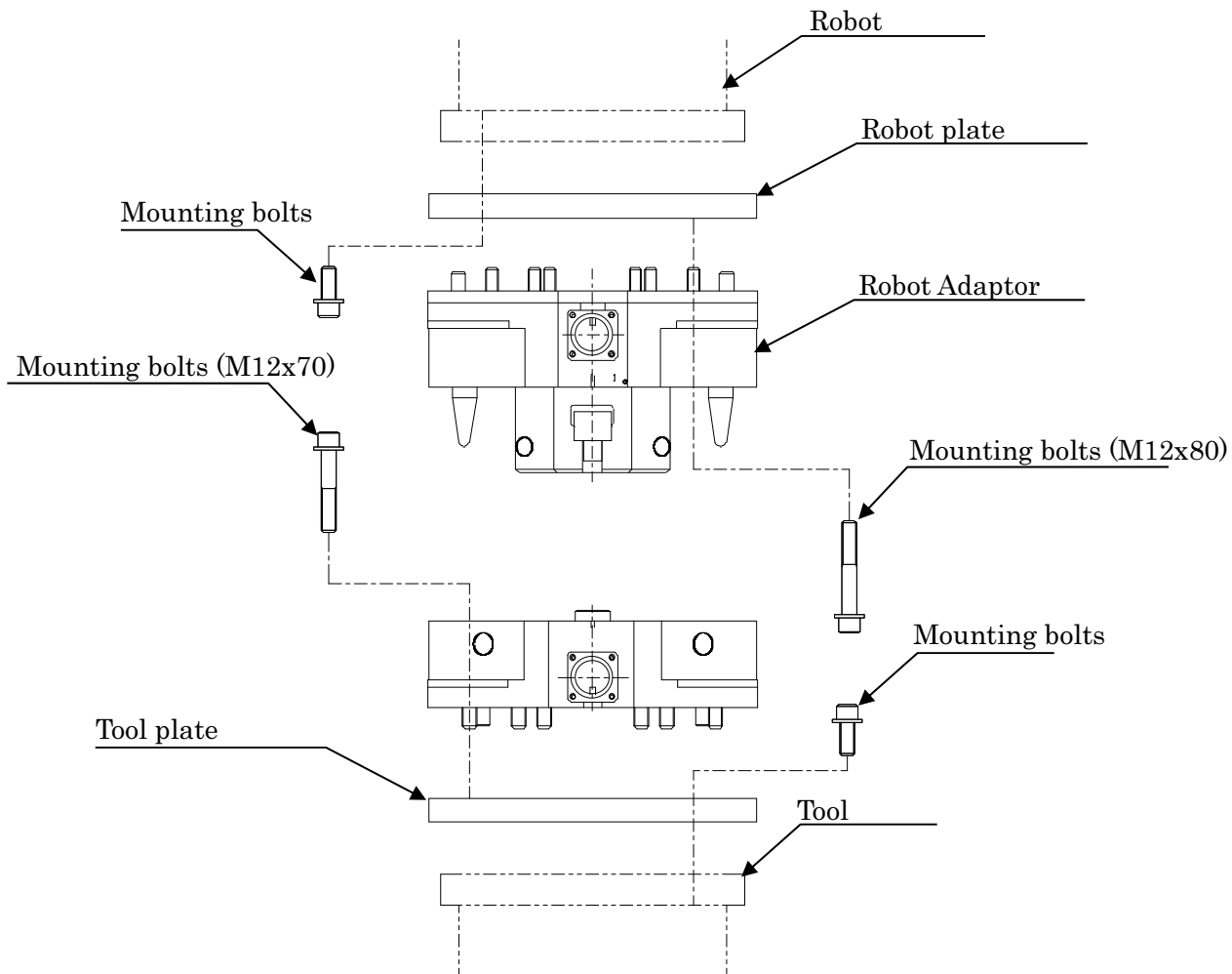

Fig. 1. System diagram

### 3. Standard Specifications

#### 3-1. Common Specifications

○Use conditions	
Ambient temperature	0-60°C (no condensation)
Ambient humidity	95%RH or below (no condensation)
Ambient atmosphere	Free of corrosive gas
Altitude	1000m or less
Vibration resistance	10-500 (Hz) Acceleration: 50 (m/s <sup>2</sup> ) for 110 minutes (compliant with IEC60068-2-6)
○Transport conditions	
Ambient temperature	-25-60°C (maximum instantaneous temperature: 70°C)
Ambient humidity	95%RH or below (no condensation)

## 3-2. ATC Specifications

### 3-2-1. ATC Specifications

Model	Robot Adaptor		See the drawing
	Tool Adaptor		See the drawing
Tare weight	Payload		400kg
	Allowable moment		2942Nm
	Allowable torque		2942Nm
	Working pressure		0.39-0.85MPa
Position reproducibility			±0.025mm
Interface	Electricity	Number of electric contacts	See the drawing
		Rated voltage	50VDC or below
		Max. allowed current	3A
		Rated frequency	50 or 60HZ
		Overvoltage category	Overvoltage category III
Allowable pollution level			Pollution level 3
Machine weight	Robot Adaptor		12.0kg
	Tool Adaptor		8.0kg
Machine dimensions	Robot Adaptor		See below *Refer to the delivery specifications for details.
	Tool Adaptor		See below *Refer to the delivery specifications for details.

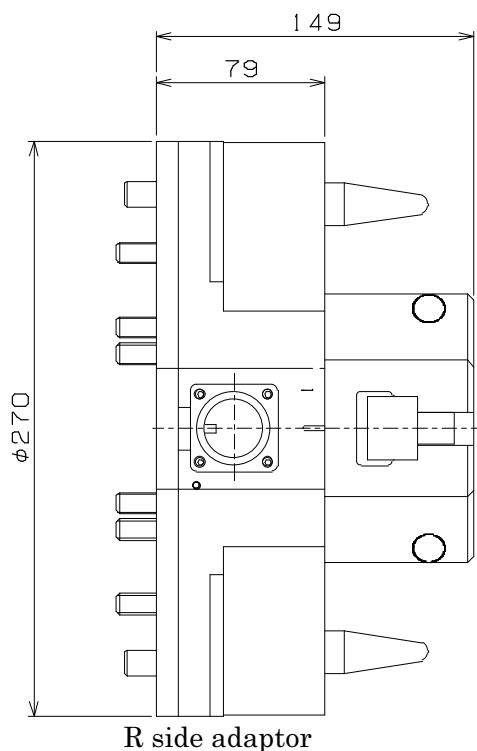

(Refer to the delivery specifications for details.)

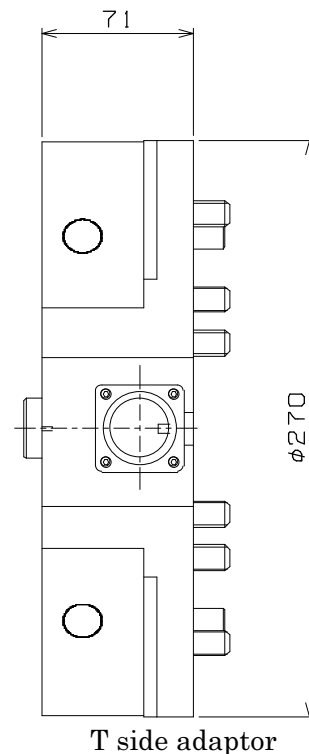

(Refer to the delivery specifications for details.)

Note: Refer to the delivery specifications.

### 3-2-2. Internal Power Wire for ATC

Name		Polyester flex-resistant power wire
Model		DKSX
Nominal sectional area		0.5mm <sup>2</sup>
Conductor	Material	Annealed copper wire for electricity
	Configuration: No. of wires/wire dia.	6/18/0.08 wires/mm
	Outer diameter	1.1mm
Insulation material	Material	Flame-retardant polyester
Withstand voltage	Under water	1000V/min
	Sparking	5000V/0.15 sec.

Name		Insulated polyester wrapping wire
Model		DKXV
Conductor	Material	Bare annealed copper wire
	Configuration: No. of wires/wire dia.	30/0.08 wires/mm
	Outer diameter	0.5mm
Insulation material	Material	Thermoplastic elastomer
Withstand voltage		500V/min

### 3-2-3. Coupling Check End Sensor

Name	Anti-spatter proximity switch		
Type	DC 2-wire shield type		
Detection method	High-frequency oscillation		
Rated power supply voltage	12/24VDC (common)		
Operating voltage range	10-30VDC		
Leak current	0.55mA or below		
Operation mode	Normally open *1		
Output mode	DC 2-wire; transistor output		
Control output	Switching current: 3-100mA    Residual voltage: 3.0V or below    Output withstand voltage: 30VDC		
Response frequency	1500Hz or above		

\*1: In proximity of detection object; load "operating"

### 3-2-4. Chuck and Unchuck Sensor

Name	Proximity switch
Type	DC 2-wire type
Detection method	High-frequency oscillation
Rated power supply voltage	12/24VDC (common)
Operating voltage range	10-30VDC
Leak current	0.55mA or below
Operation mode	Normal open *1
Output mode	DC 2-wire; transistor output
Control output	Switching current: 3-100mA    Residual voltage: 3.0V or below    Output withstand voltage: 30VDC
Response frequency	2000Hz or above

\*1: In proximity of detection object; load "operating"

### 3-2-5. LED ASSY Specifications

This section describes specifications of photo couplers used in the LED ASSY equipped on the robot adaptor. For details, please refer to the specifications, etc.

Model	TLP523 (Toshiba)
Type	Red LED + Photodarlington transistor
Dielectric voltage	2500Vrms (minimum)
Collector-emitter breakdown voltage	55V (minimum)
Conversion efficiency	500% (minimum) (IF=1mA)
Collector-emitter saturation voltage	1.0V (maximum) (IC=50mA)
High temperature dark current	10μA (maximum) (Ta=85°C)
UL-certified	UL1577 (File No.E67349)



### 3-1. Spot Welding Module Specifications (Seal Connector Specifications)

#### 3-3-1. Spot Welding Module Specifications

Model	Robot Side	See the drawing
	Tool Side	See the drawing
Weight	Robot Side	1.0 kg
	Tool Side	1.0 kg
Material		Voltage-proof resin
Overvoltage category		Overvoltage category III
Rated voltage		Single-phase 600VAC
Max. allowed current		100A
Rated frequency		1000HZ
Allowable pollution level		Pollution level 3

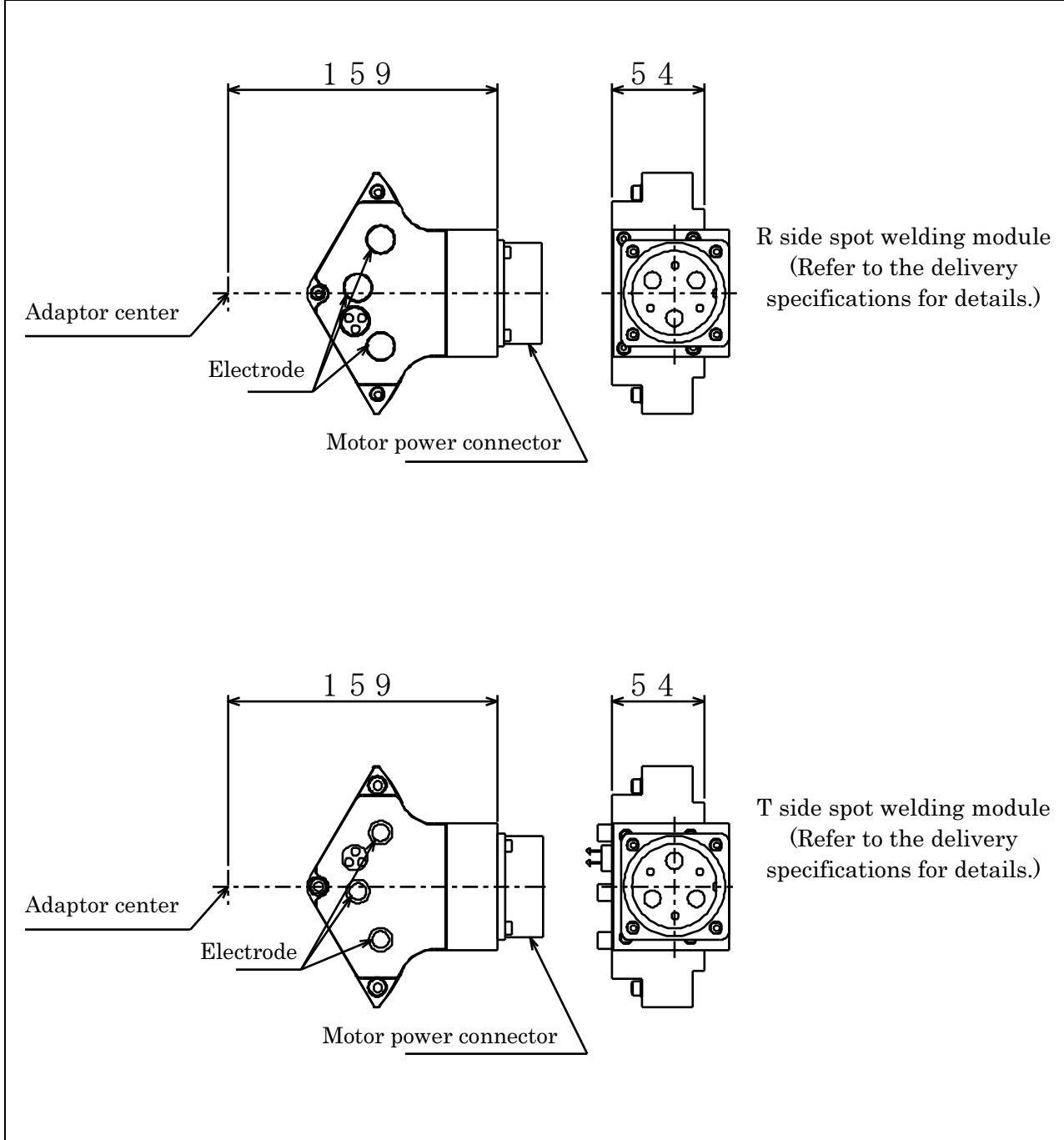

**3-3-2. Internal Power Wire for Spot Welding Module (Power)**

Name		Natural rubber insulation for holder Natural rubber sheath cable	
Nominal sectional area		22mm <sup>2</sup>	
Conductor (AC)	Material	Soft-copper stranded wire	
	Configuration: No. of wires/wire dia.	7/7/22/0.16 wires/mm	
	Outer diameter	6.6mm	
Insulation material	Material	Natural rubber mixture	
Withstand voltage (under water)		2000V/5 min	
Allowable current (30°C)	Usage (%)	100	121A
		80	135A
		50	171A

**3-3-3. Internal Power Wire for Spot Welding Module (Earth)**

Internal wire in modules (earth)		Polyvinyl chloride wire for electric appliances	
Nominal sectional area		14mm <sup>2</sup>	
Conductor	Material	Soft-copper stranded wire	
	Configuration: No. of wires/wire dia.	88/0.45 wires/mm	

### 3-4. Spot Welding Module Specifications (Seal Connector Specifications)

#### 3-4-1. Spot Welding Module Specifications

Model	Robot Side	See the drawing
	Tool Side	See the drawing
Weight	Robot Side	1.0 kg
	Tool Side	1.0 kg
Material		Voltage-proof resin
Overvoltage category		Overvoltage category III
Rated voltage		Single-phase 600VAC
Max. allowed current		100A
Rated frequency		1000HZ
Allowable pollution level		Pollution level 3

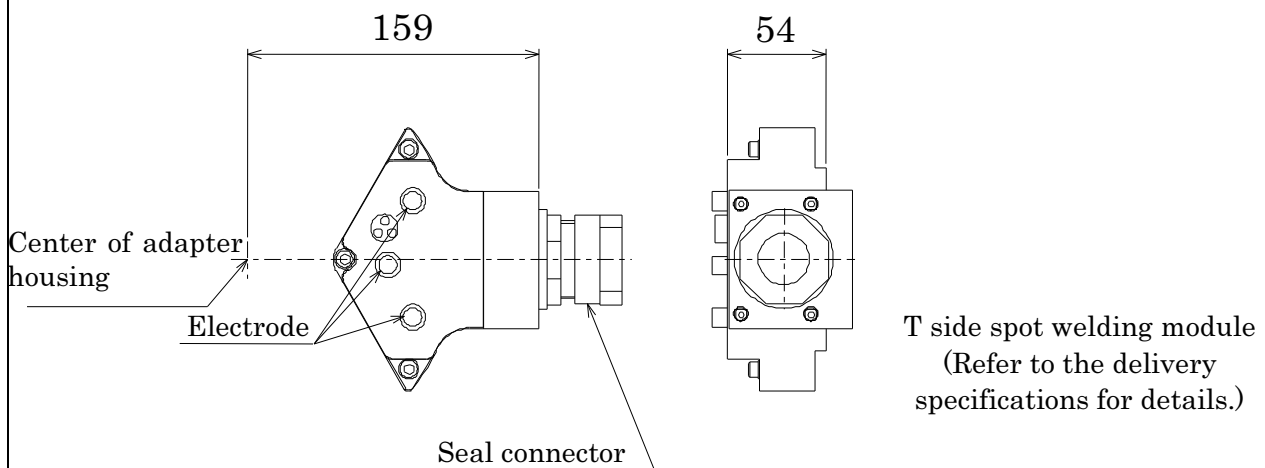
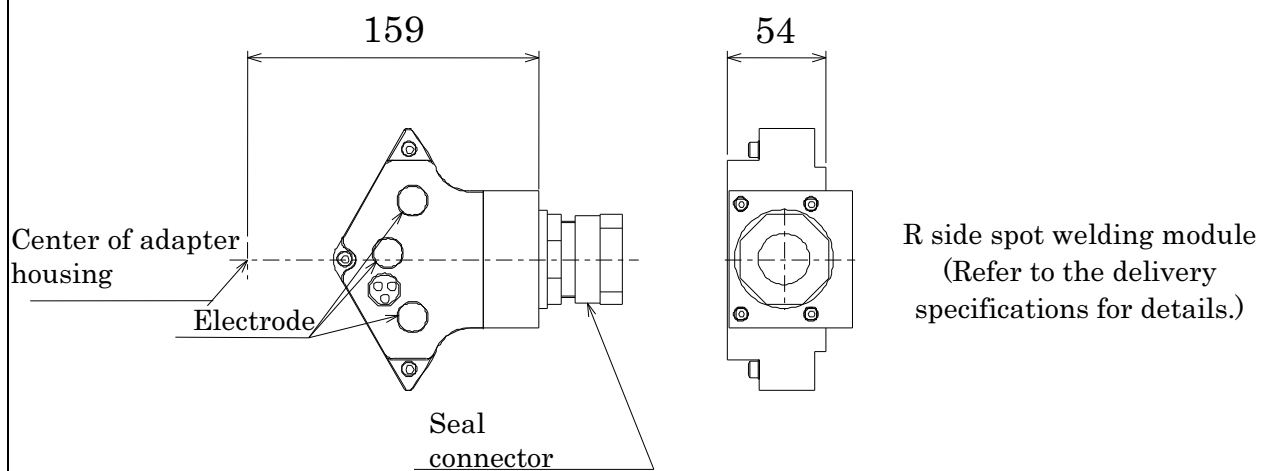

### 3-5. Servo Motor Module Specifications

#### 3-5-1. Servo Motor Module Specifications

Model	Robot Side	See the drawing
	Tool Side	See the drawing
Specification	Motor power	6 electrodes
	Signal	15 electrodes
Weight	Robot Side	0.8kg
	Tool Side	0.8kg
Material		Voltage-proof resin
Overvoltage category		Overvoltage category III
Rated voltage	Motor power	200VAC
	Signal	50VDC or below
Max. allowed current	Motor power	20A
	Signal	3A
Rated frequency		50 or 60HZ
Allowable pollution level		Pollution level 3

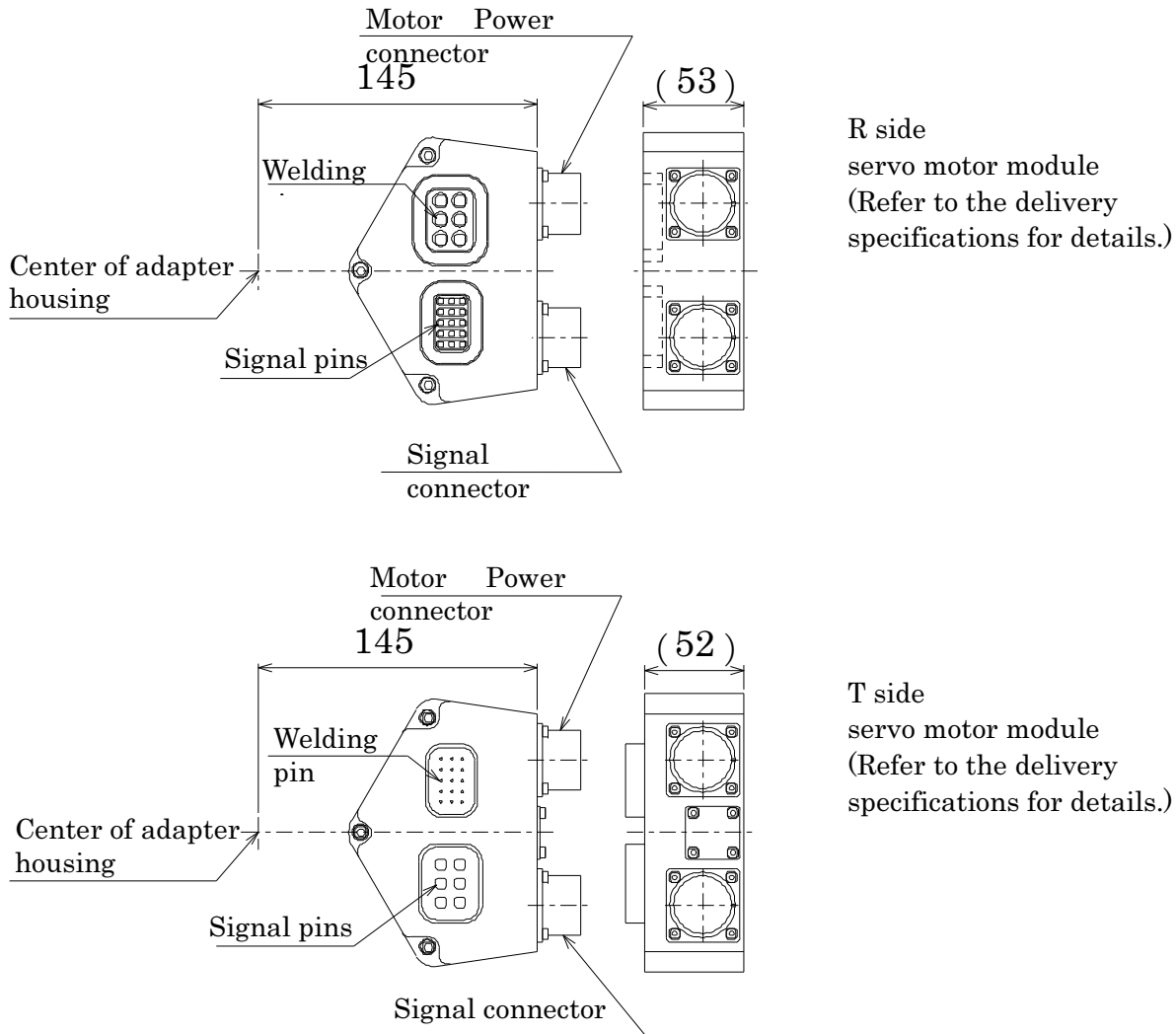

3-5-2. Internal Power Wire for Servo Motor Module

Motor power			
Name		Brake	Power
Model		CE-531XXSB 0.75x2	MVVS 1.25x4
Nominal sectional area		0.75mm <sup>2</sup>	1.25mm <sup>2</sup>
Conductor	Material	Soft-copper stranded wire	Soft-copper stranded wire
	Configuration: no. of wires/wire dia.	67/0.12 wires/mm	50/0.18 wires/mm
Insulation material	Material	Heat-resistant vinyl mixture	Heat-resistant vinyl mixture

Signal		
Name		Cable for durable robot
Model		KDF-SB
Nominal sectional area		0.5mm <sup>2</sup>
Conductor	Material	Soft-copper composite stranded wire
	Configuration: no. of wires/wire dia.	3x(33/0.08) wires/mm
Insulation material	Material	Natural rubber mixture
Final diameter		About 13mm
Withstand voltage		1500VAC/min

### 3-6. Hydraulic Module Specifications (Rc3/8 Specifications)

Model	Robot Side	See the drawing
	Tool Side	See the drawing
Number of hydraulic ports		4
Fluid used		Water, air
Fluid temperature		0-80°C (no condensation)
Ambient temperature		0-60°C
Ambient humidity		95%RH or less
Normal pressure		0.86MPa
Effective sectional area		21.7 (mm <sup>2</sup> )/PORT
Cv value		1.33/PORT
Connecting screw size		Rc3/8
Machine weight	Robot Side	1.0(kg)
	Tool Side	0.8(kg)

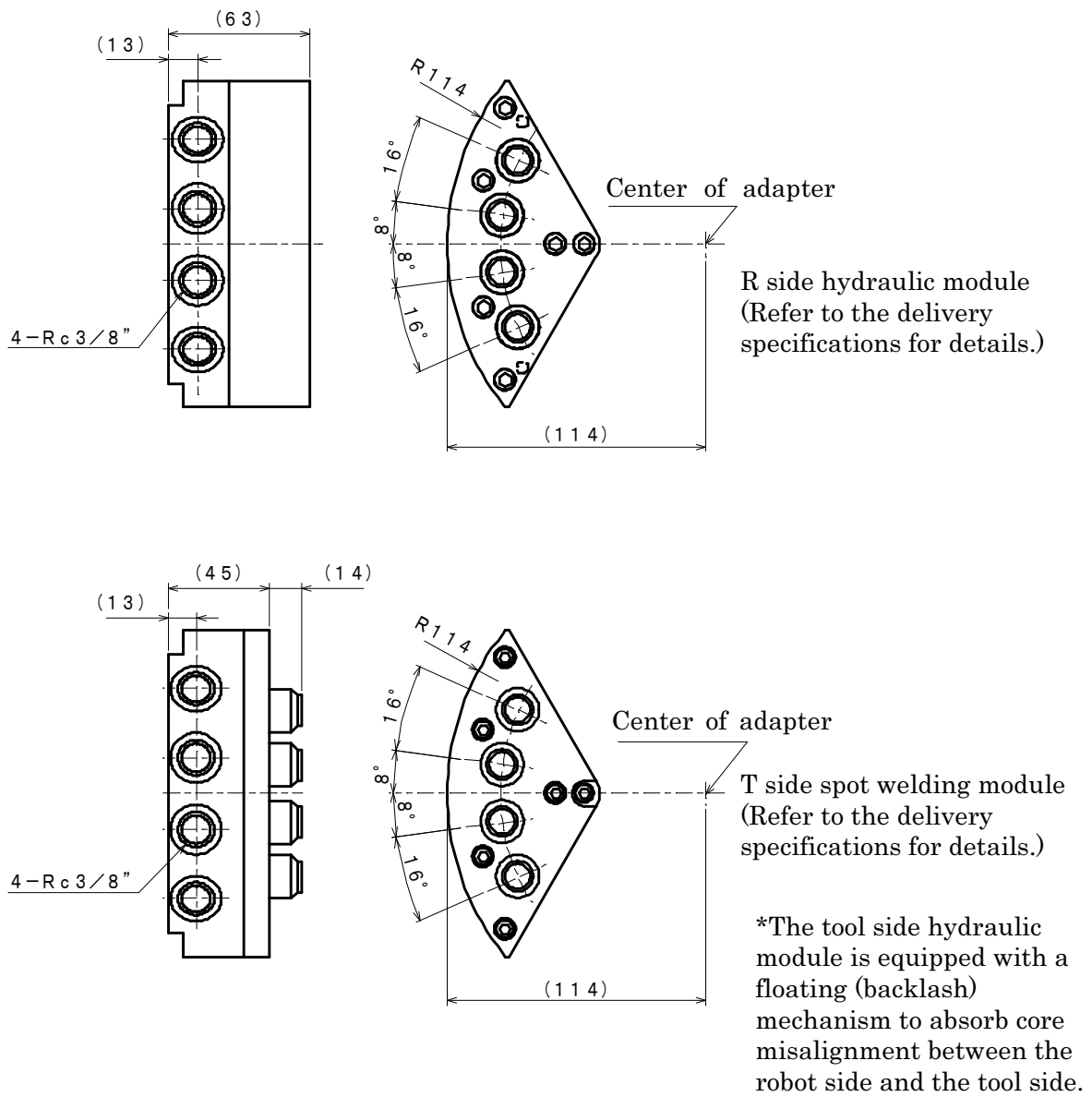

### 3-7. Hydraulic Module Specifications (Rc1/2 Specifications)

Model	Robot Side	See the drawing
	Tool Side	See the drawing
Number of hydraulic ports		4
Fluid used		Water, air
Fluid temperature		0-80°C (no condensation)
Ambient temperature		0-60°C
Ambient humidity		95%RH or less
Normal pressure		0.86MPa
Effective sectional area		60.0(mm <sup>2</sup> )/PORT
Cv value		3.4/PORT
Connecting screw size		Rc1/2
Machine weight	Robot Side	1.2(kg)
	Tool Side	1.2(kg)

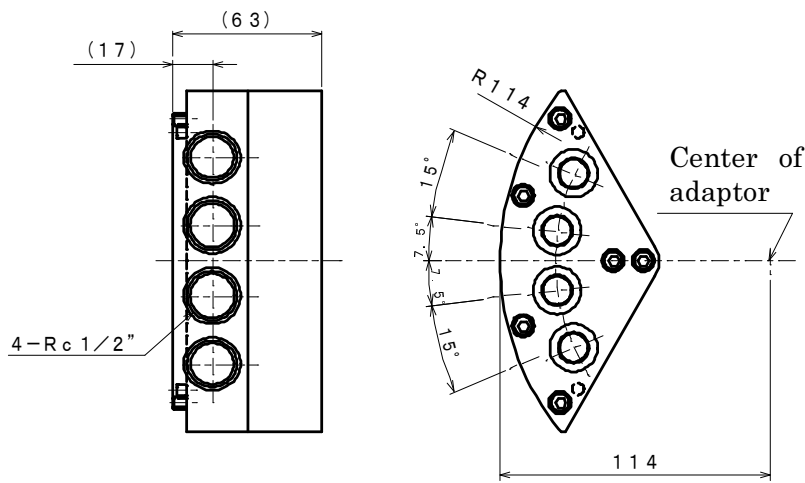

R side hydraulic module  
(Refer to the delivery specifications for details.)

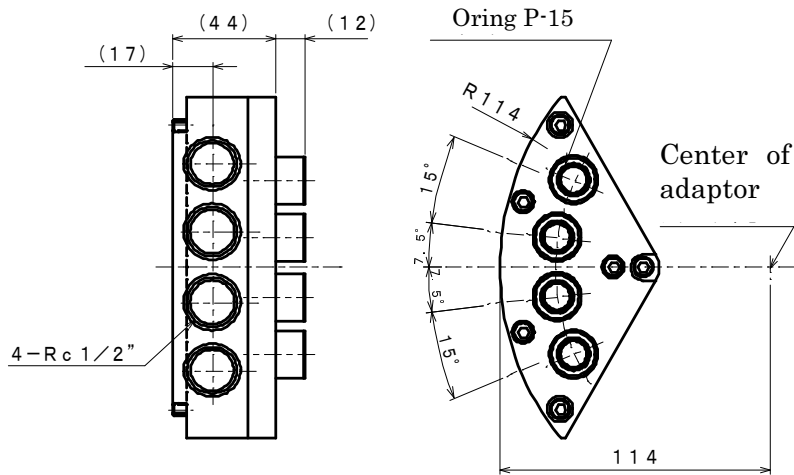

T side hydraulic module  
(Refer to the delivery specifications for details.)

\*The tool side hydraulic module is equipped with a floating (backlash) mechanism to absorb core misalignment between the robot side and the tool side.

### 3-8. Pneumatic Module Specifications (Rc1/4 Specifications)

Model	Robot Side	See the drawing
	Tool Side	See the drawing
Number of Pneumatic ports		4
Fluid used		Air
Fluid temperature		0-80°C (no condensation)
Ambient temperature		0-60°C
Ambient humidity		95%RH or less
Normal pressure		0.86MPa
Effective sectional area		19.0(mm <sup>2</sup> )/PORT
Cv value		0.72/PORT
Connecting screw size		Rc1/4
Machine weight	Robot Side	1.0(kg)
	Tool Side	0.8(kg)

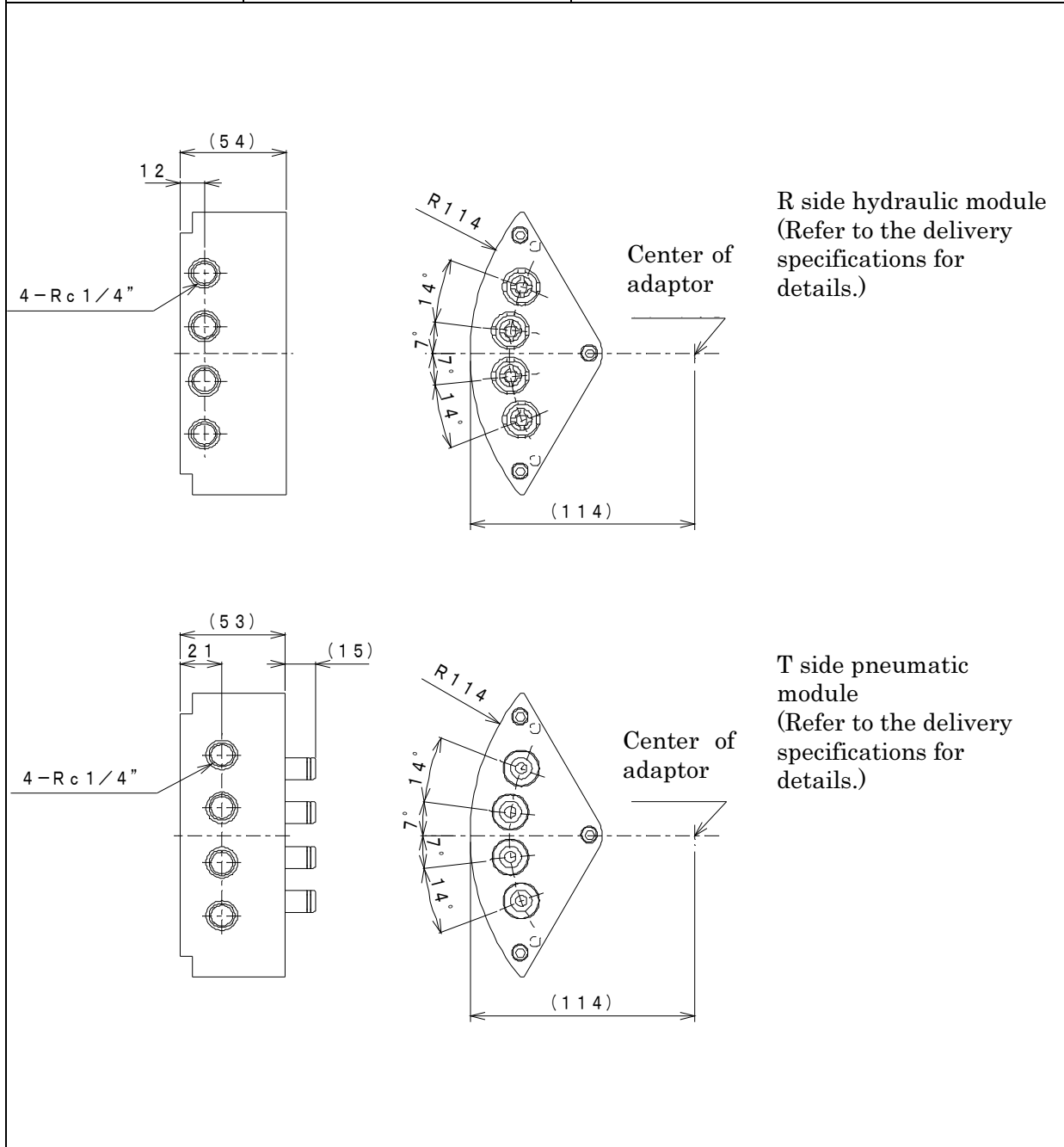



### 3-9. Pneumatic Module Specifications (Rc1/2 Specifications)

Model	Robot Side	See the drawing
	Tool Side	See the drawing
Number of hydraulic ports		4
Fluid used		Air
Fluid temperature		0-80°C (no condensation)
Ambient temperature		0-60°C
Ambient humidity		95%RH or below (no condensation)
Normal pressure		0.86MPa
Effective sectional area		61.0(mm <sup>2</sup> )/PORT
Cv value		3.4/PORT
Connecting screw size		Rc1/2
Machine weight	Robot Side	1.0(kg)
	Tool Side	0.8(kg)

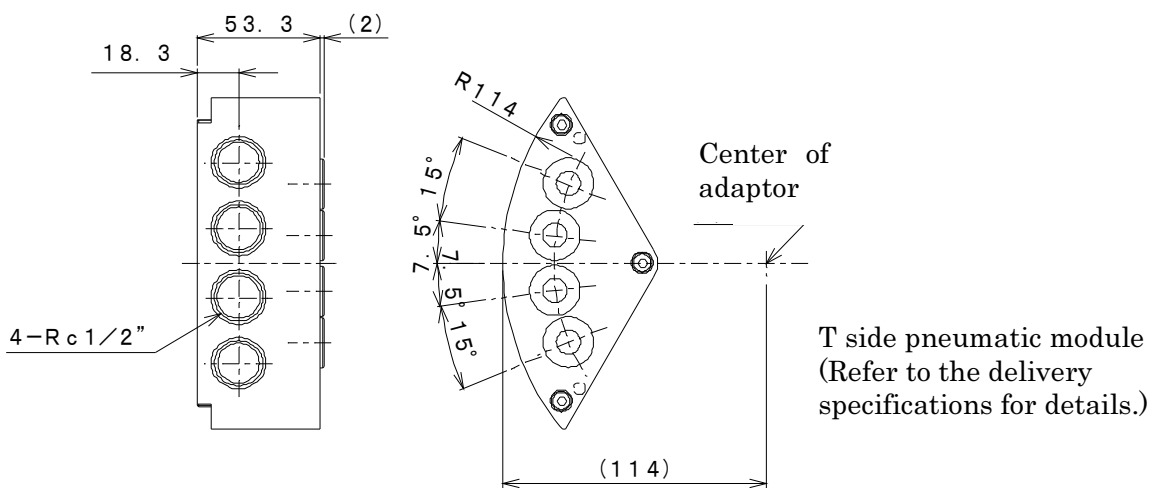
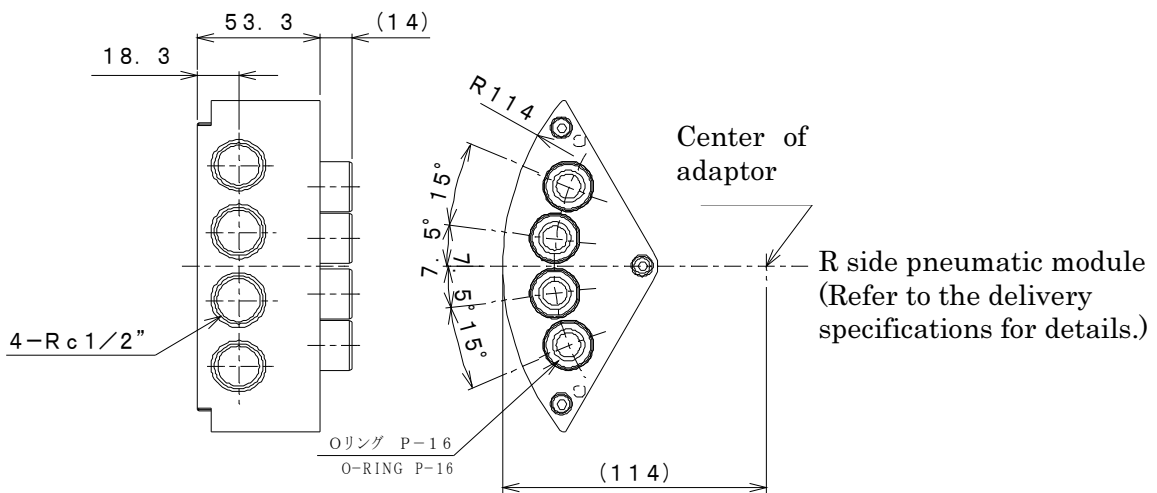

### 3-10. Signal Module Specifications

#### 3-10-1. Signal Module Specifications

Model	Robot Side	See the drawing
	Tool Side	See the drawing
Specification		35 electrodes
Weight	Robot Side	0.5kg
	Tool Side	0.5kg
Material		Voltage-proof resin
Rated voltage		50VDC or below
Max. allowed current		5A
Rated frequency		50 or 60HZ
Overvoltage category		Overvoltage category III
Allowable pollution level		Pollution level 3

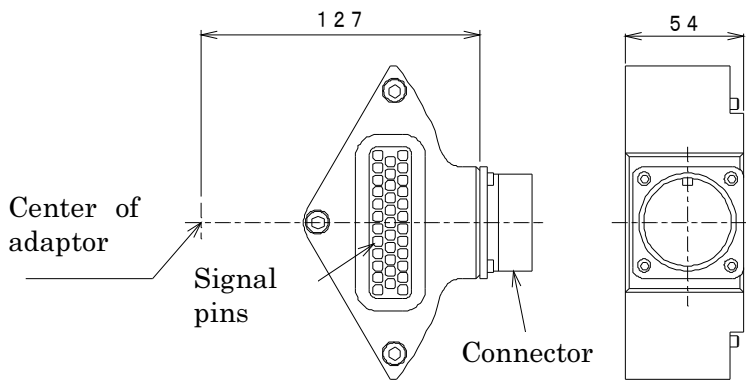

R side signal module  
(Refer to the delivery specifications for details.)

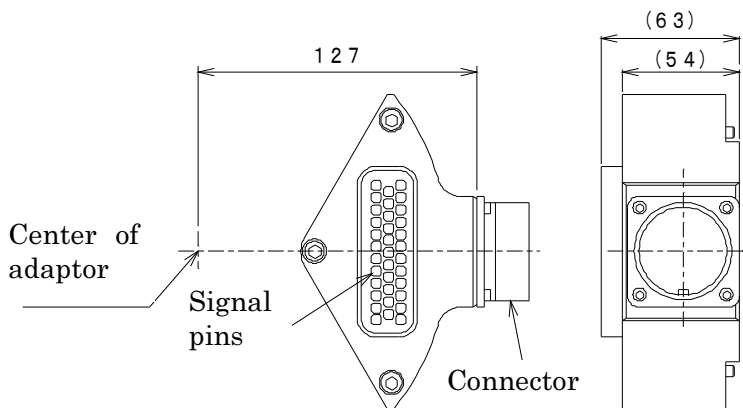

T side signal module  
(Refer to the delivery specifications for details.)

### 3-10-2. Internal Power Wire for Signal Module

Internal power wire		
Name		Polyester flex-resistant power wire
Model		DKSX
Nominal sectional area		0.5mm <sup>2</sup>
Conductor	Material	Annealed copper wire for electricity
	Configuration: No. of wires/wire dia.	6/18/0.08 wires/mm
	Outer diameter	1.1mm
Insulation material	Material	Flame-retardant polyester
Withstand voltage	Under water	1000V/min
	Sparking	5000V/0.15 sec.

### 3-11. Fall Protection System Specifications

Product No.	CAR-006-**
External dimensions (height x width x thickness)	64x70x73mm
Main unit material	Aluminum alloy
Weight	0.98kg
Effective sectional area (Cv value)	6mm <sup>2</sup> (0.33)
Fluid used	Air
Working pressure	0-0.99MPa
Ambient temperature and working air temperature	0-60°C
Joint diameter (nominal)	Rc(PT)1/8(6A)
Grease up	Not required/Class 1 turbine oil if used (ISOVG32)

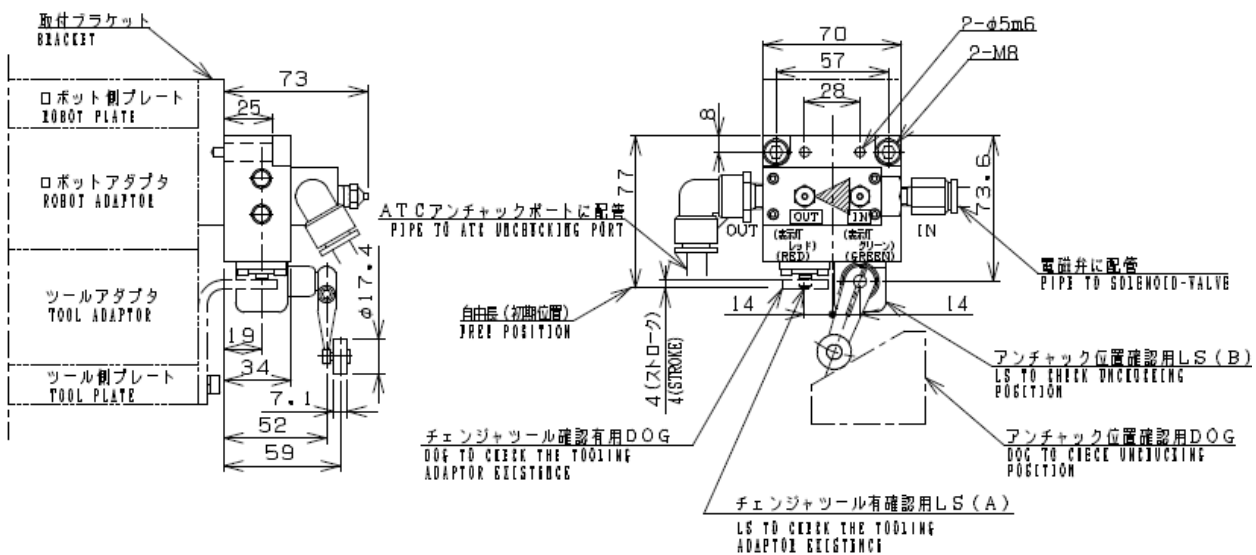

(Refer to the delivery specifications for details.)

**⚠ CAUTION**

- Ensure that there is no problem with piping.
- Ensure that the lever and DOG positions are as per the delivery specifications.

**⚠ WARNING**

Perform installation carefully not to bend the tube connected with the chuck/unchuck port during robot motions. Otherwise, it may fall off.

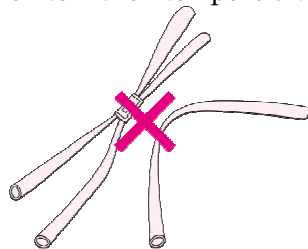

- Tube bending
- Tube twisting
- Excessive tightening of tube with banding band

### 3-12. Precautions for Allowable Load and Installation

**⚠ WARNING**

Rated load, rated moment, and rated torque of the ATC are dynamic specifications for the unit being mounted on a robot.

Ensure that the maximum load never exceeds these values during normal operations taking into account the acceleration factor and inertia during acceleration/deceleration by the robot. Figure 3 shows the meanings of rated load, rated moment and rated torque.

Payload	$W = 3920\text{N} (400\text{kg})$
Eccentric distance	$L = \sqrt{(lm^2 + lt^2)}$
Allowable bending moment	$M = L \times W \times GR^{(*)} = 0.5 \times 3920 \times 1.5 \leq 2942\text{N}\cdot\text{m} \{30000\text{Kgf}\cdot\text{cm}\}$
Allowable twisting torque	$T = L_t \times W \times GR^{(*)} = 0.5 \times 3920 \times 1.5 \leq 2942\text{N}\cdot\text{m} \{30000\text{Kgf}\cdot\text{cm}\}$

Note:  $GR^{(*)}$  is the acceleration factor of constant acceleration/deceleration in automatic robot operations. For specific values of robot performance, please contact the robot manufacturer for further consideration. (Use 1.5-2.0G as a standard.)

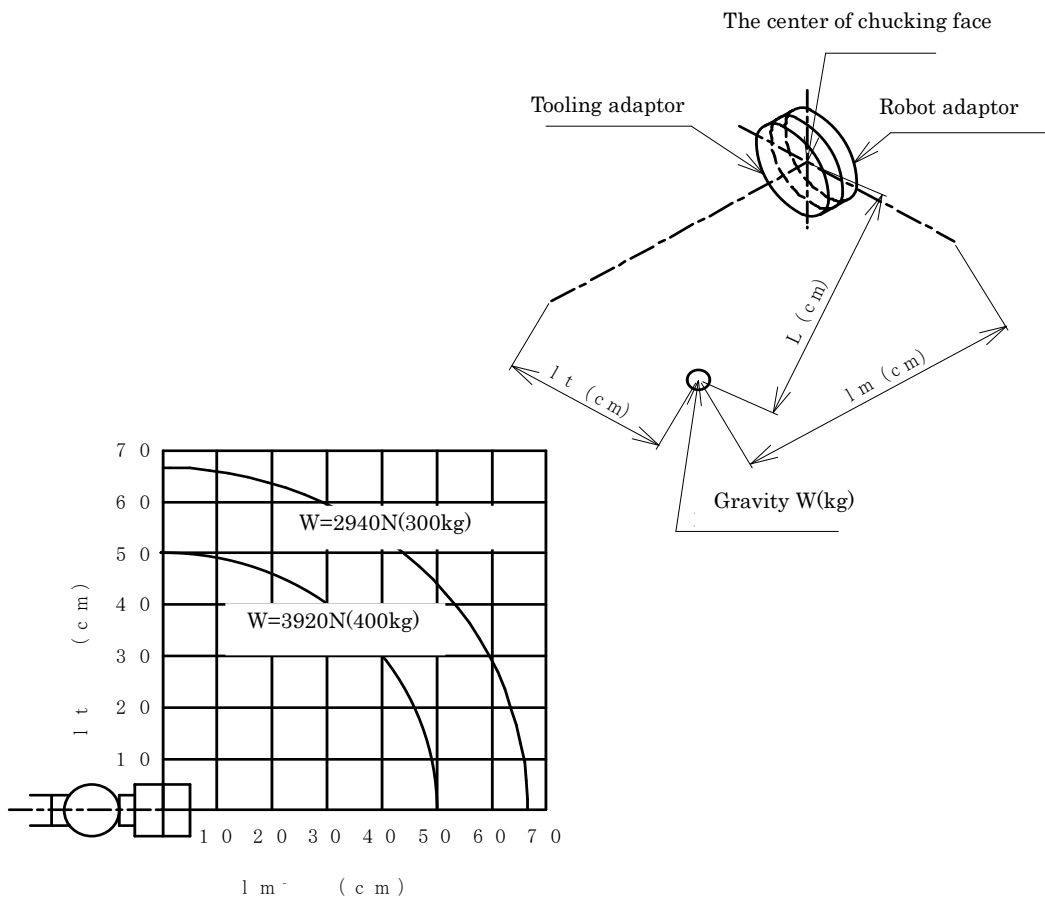

Fig. 2. An example of rated load definition ( $GR = 1.5$ )

### 3-13. Allowable Electric Load

**⚠ CAUTION**

The ATC with the standard signal pin ASSY (20-pin), as an entire contact ASSY, is capable of carrying up to 13A current. Also, each of the pins is capable of carrying 110V 3A current. However, when multiple signal pins are to be used, do not let 3A current applied to any adjacent pin as it will cause insufficient insulation, leading to short circuit.

## 4. Part Names

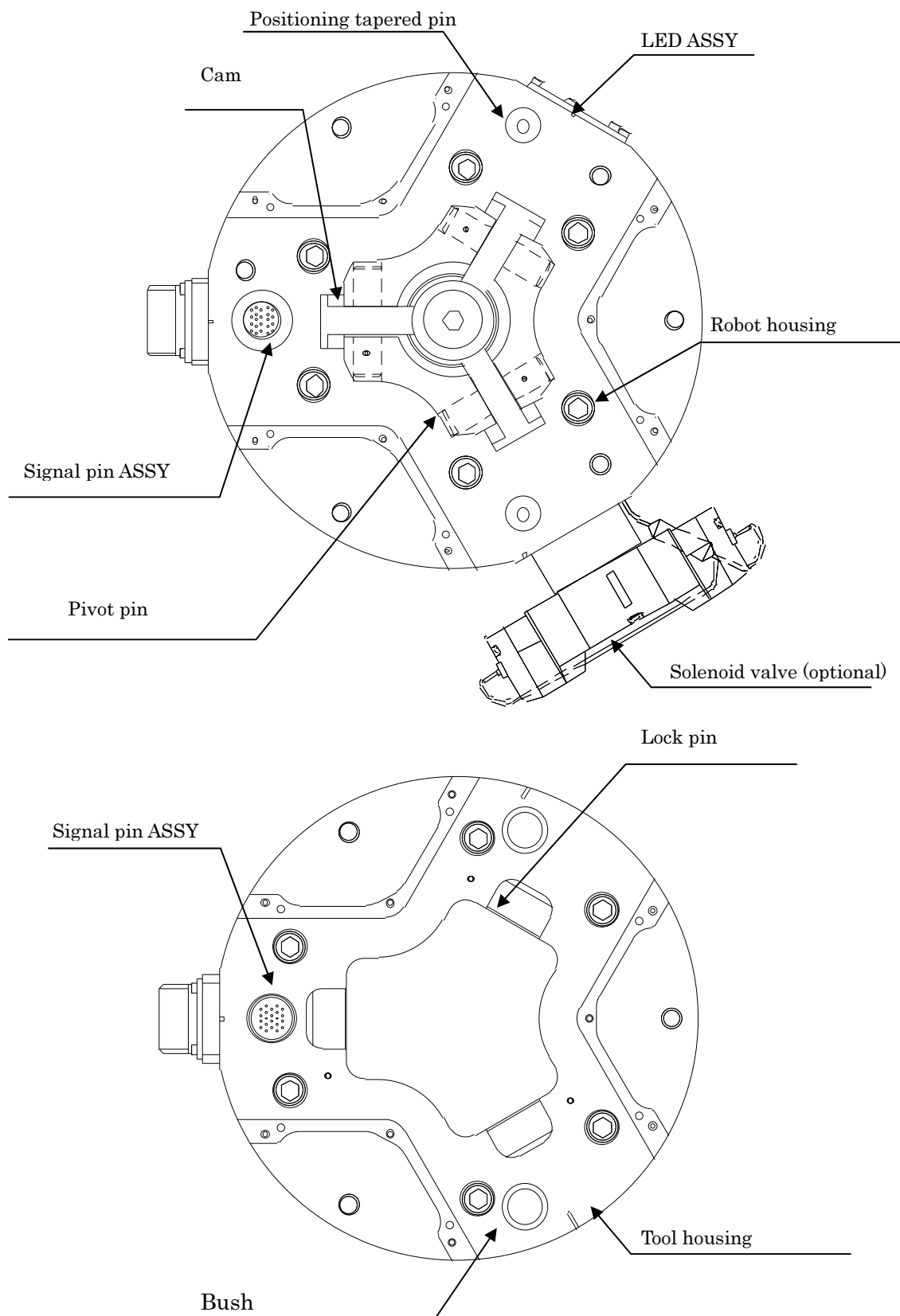

Fig. 3. Part names

## 5.Procedures of Installation to Robot/Tool

---

**⚠ DANGER** For use of ATC, be sure to observe safety instructions concerning core robots and compatible units. For any work within the robot safety fence, consider preparing a safety system design to shut down power over 50V once any person gets into the fenced area.

---

**⚠ WARNING** In addition, for works in the safety fence area, be sure to wear appropriate clothing for the work with personal protective equipment such as a hard hat, safety boots, etc. For internal disassembly works for the ATC, use protective glasses for protection against pop-out parts.

---

**⚠ CAUTION** Personnel engaged in installation, programming and maintenance works inside the robot safety fence for the ATC must have expertise in robot operations (having completed expert training). In addition, those engaged in disassembly or assembly works of the ATC, whether in or out of the safety fences, shall read this document, installation guide, and maintenance procedures.

---

### 5-1. Robot Adaptor

To install a robot adaptor to a robot, remove the robot adaptor plate (optional) from the robot adaptor and drill the plate to make appropriate mounting holes (or threads) for the robot. Mount the robot adaptor plate to the robot first and then mount the robot adaptor on it. (Refer to "Fig. 1. System diagram.")

Mounting bolt: M12x65 x 6 pcs. [Torque: 80Nm]  
(\*Used with M12 disc spring washers)

### 5-2. Tool Adaptor

Tool adaptor is also composed of a tool adaptor unit and a tool adaptor plate (optional). To use the tool adaptor plate (optional), remove the tool adaptor plate from the tool adaptor unit, drill the plate to make mounting holes or threads appropriate for the tool, and then mount the tool adaptor. (Refer to "Fig. 1. System diagram.")

Mounting bolt: M12x60 x 6 pcs. [Torque: 80Nm]  
(\*Used with M12 disc spring washers)

---

**⚠ CAUTION** Our robot and tool adaptor plates are temporarily assembled with a respective robot and tool adaptor in plant but their screws are not fully tightened. Before installation, therefore, please remove the mounting screws of the robot/tool adaptor even if there is no need for separating the adaptor from a respective plate.

---

---

**⚠ CAUTION** If you manufacture (process) a robot/tool adaptor plate on your own, be sure to ensure sufficient depth of counterbore so that the head of any mounting screw will not protrude from the mounting surface of each adaptor plate. When using male screws from the tool side to attach a tool to a tool adaptor, adjust the bolt length so that the tip of any male screw will not protrude from the tool adaptor plate surface.

---

---

**⚠ CAUTION** Check that a parallel pins ( $\phi 10 \times 2$ ) are inserted to the mounting surface of the robot and tool adaptor before attachment.

---

**⚠ CAUTION** Be sure to use locking agent (low strength) for mounting bolts when tightening them.

---

Tighten bolts in the order of the numbers in steps so that equal force is applied to each bolt.

E.g. Tightening screws in a criss-cross pattern starting with ①, ②, ③ and so on.

**⚠ CAUTION**

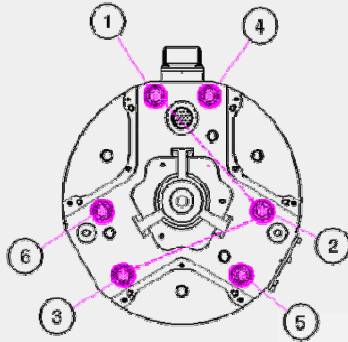

For the installation work, set the robot flange surface facing upward at the height of your breast to prevent ATC from falling.

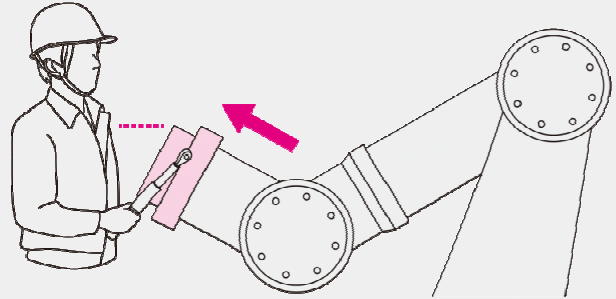

Fig. 4. Bolt tightening sequence and precaution

---

**⚠ CAUTION** Tightening bolts with torque above the specified torque level may damage threads on the ATC side and modules. Further, tightening bolts with torque below the specified torque level or failure to use the locking agent may cause bolts to be loosened, leading to module fall off.

---



### 5-3. Connecting to Fitting/Removal Port

Connect the solenoid valve to the "CHUCK" port and "UNCHUCK" port of the fitting/removal mechanism. The constant pressure line (with the valve not energized) must always be connected with the "CHUCK" port to maintain coupling of the chuck/unchuck port in the event of power failure.

#### WARNING

Be sure to shut off the power supply, air, water and hydraulic power before starting the work.

- Be careful to ensure tubes are connected to right ports (chuck port (CH) and unchuck (UN) port). Otherwise the tool may fall off.
- Clearly mark the chuck (CH) and unchuck (UN) tubes accordingly.
- Securely insert the tubes to the end to prevent accidental disconnection.
- There are two types of chuck/unchuck air piping: standard spec and solenoid valve spec (a robot adaptor with solenoid valve).
- For the solenoid valve spec, there are one air supply port.
- Do not manually switch the air supply without an absolute need to do so.

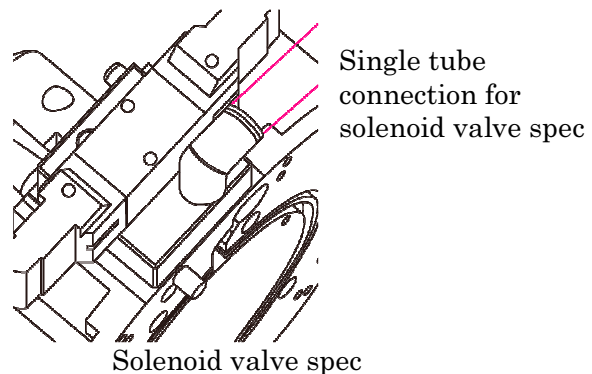
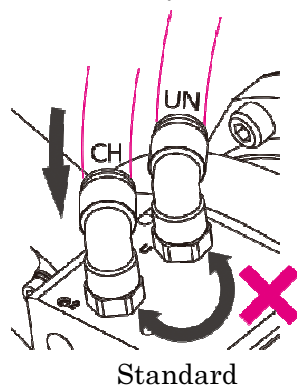

#### WARNING

Leave the "UNCHUCK" port opened without plugging even when chuck/unchuck is not to be performed (in a coupled state only). Also, be sure to pressurize the "CHUCK" port when using it. Otherwise, it may fall off.

#### DANGER

About air piping for ATC driving:

ATC has a fail-safe mechanism to prevent the tool side from falling even when air pressure is unexpectedly decreased. However, the air piping for ATC driving requires proper selection and arrangement of solenoid valve to prevent air from flowing into the "unchuck" side even when the valve is electrically turned OFF.

- Do not use any three-position, closed-center type solenoid valve. The chucked state cannot be maintained with the power supply turned OFF, which may result in falling.
- Do not share an exhaust port with other equipment. Otherwise, the chucked state cannot be maintained due to wrap-around back pressure, which may result in falling.
- Do not branch the air supply to the "CHUCK" port to other equipment. Otherwise, the chucked state cannot be maintained due to reduced pressure, which may result in falling.

- 
- ⚠ WARNING** Perform installation carefully not to bend the tube connected with the chuck/unchuck port during robot motions. Otherwise, it may fall off.

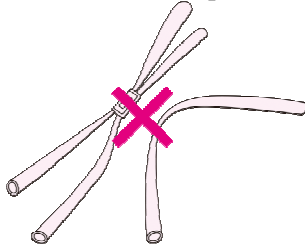

- Tube bending
- Tube twisting
- Excessive tightening of tube with banding band

- 
- ⚠ WARNING** Do not cap the exhaust port of the solenoid valve used for switching pressure on the chuck/unchuck port. Otherwise, it may fall off.

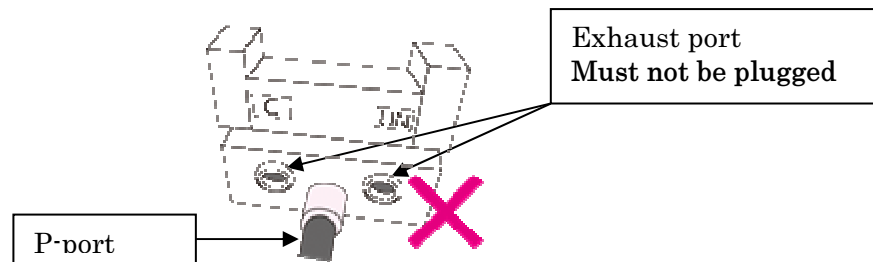

- 
- ⚠ CAUTION** As a solenoid valve used for switching pressure on the chuck/unchuck port, select a double-solenoid type valve. Then effects of any noise malfunction are mitigated.

#### 5-4. Electric Wiring

With reference to the internal wiring chart, connect the input and output wires to robot adaptor terminals. Connect the built-in sensors to a robot (line, etc.) control system. Signals from these sensors will be taken through the aforementioned terminals. In case of the connector spec, be sure to securely insert the connectors.

- 
- ⚠ WARNING** Perform wiring as per the delivery specifications. Improper wiring may cause failure or electric leakage, etc.

- 
- ⚠ WARNING** Securely apply Class III grounding for earth and shield lines. Otherwise, electric shock and noise may occur, leading any malfunctions.

#### 5-5. Cable Fixing

- 
- ⚠ CAUTION** Robot side cables must be securely tied together with other cables and tubes and fixed around the robot adaptor's connector part by using a spiral tube or banding band, etc. Also ensure that cables and tubes are free of any excessive force while the robot's wrist axis is rotating. Excessive force applied onto cables and tubes may break a connector of the joint part and an electric module, etc. or cause open-circuit. It may also cause any electric shock hazard and sparking. An example of cable fixing by a bracket is shown in Fig. 5.

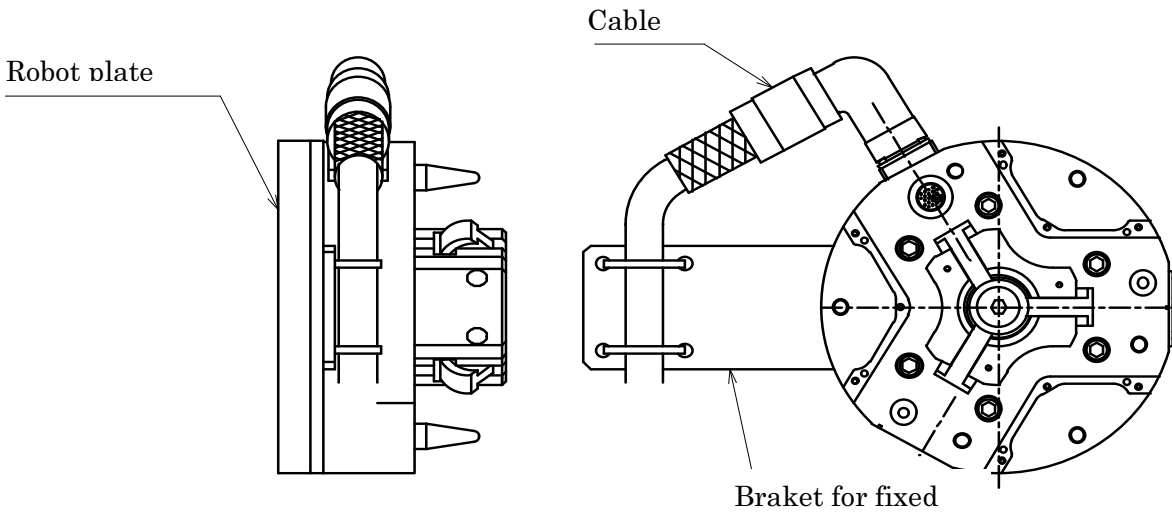

Fig. 5. An example of cable fixing

## 5-6. Precautions for Installing ATC to a Tool

### 5-6-1. ATC Orientation

- ◆ **MEMO** In order to minimize the gap between mating surfaces, it is recommended to install ATC so that the maximum possible load center is oriented as illustrated in the figure below.

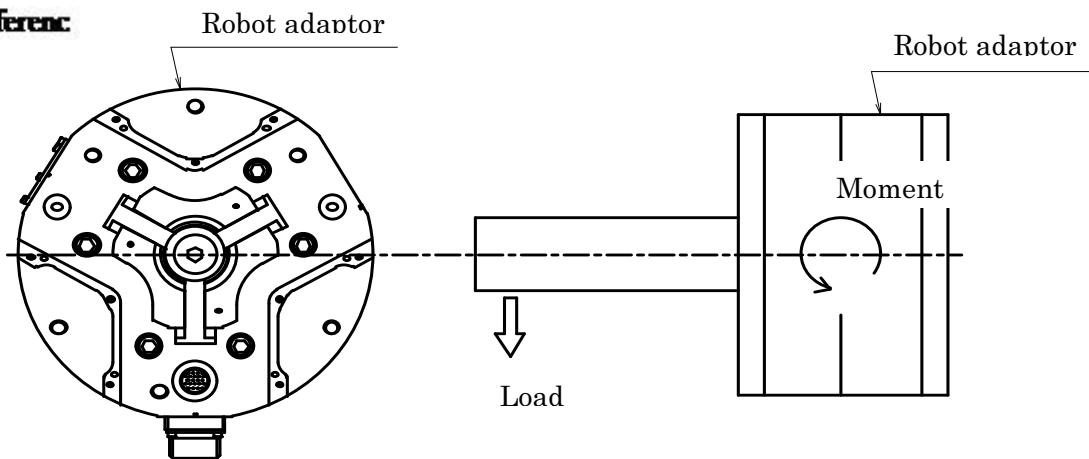

Fig. 6. ATC Orientation

### 5-6-2. ATC Grease Up

Pressure-, heat-, and water-resistant mineral lithium composite grease or lithium grease should be applied thinly and evenly to external sliding faces (10 points in total).

For new products, please check that grease has been already applied in plant. Application points are indicated in Figure 7. (Recommended grease: SUMIPLEX BN NO. 1 (manufactured by Sumico Lubricant))

---

**CAUTION** Do not use molybdenum grease.  
As Nitta uses mineral lithium composite grease, be sure to use the same type of grease. Recommended NLGI No. (JIS consistency number) is No.1 and No.2.

---

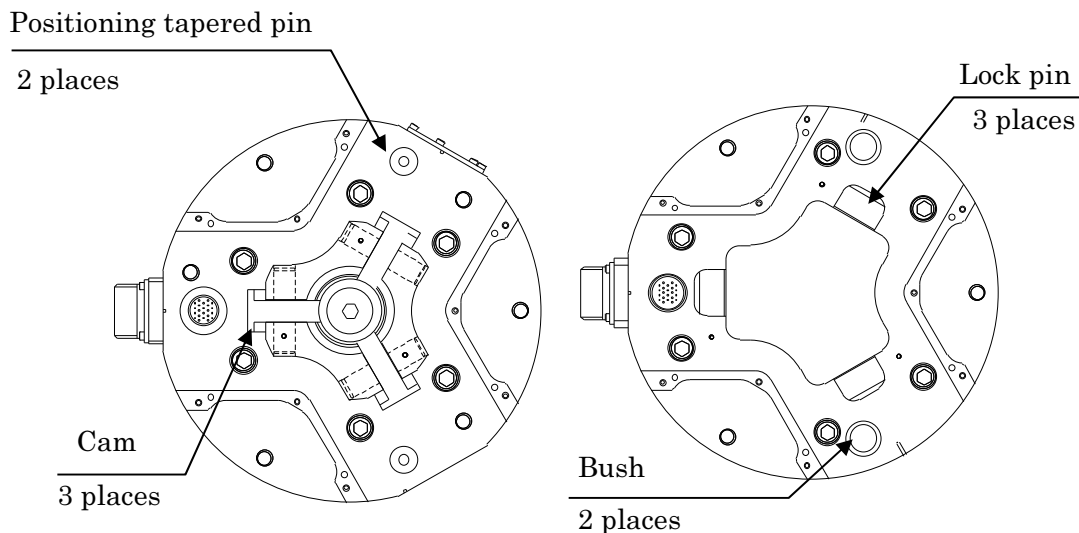

Fig. 7. ATC greasing points

---

**CAUTION** Without greasing, prying and early wear will be generated on each part.

---

### 5-6-3. Proximity of ATC

**MEMO** The ATC may be detached manually in case of emergency by following the procedure described later. However, if the lock pin holes, etc. on the tool adaptor are capped with a terminal box on the tool, etc., jigs may not be inserted and compulsory detaching is prevented. Ensure that there is not interference.

### 5-6-4. 5-6-4. Precautions for using a servo motor for a tool

**MEMO** If you use a tool with a servo motor (servo gun/servo material handling equipment, etc.), install a battery for memory storage on the tool side or use an encoder with no need for powered memory storage in preparation for power failure to the encoder for separation.  
In addition, functionality to electrically disconnect/connect the servo motor is necessary on the robot.

---

## 5-7. Torque Level for Modules.

Chart 1. Module assembly bolts and torque level \*1

	R side		T side	
	Spot welding servo signal	Screw shape	M5X40 SUS Spring water + Flat washer With MEC processing (low strength 222)	Screw shape
Nitta model No.		GWAP05040M	Nitta model No.	GWAP05040M
Torque		5Nm	Torque	5Nm
Remarks		Embedded screw	Remarks	Embedded screw
Spot welding signal	R side		T side	
	Screw shape	M5X45 SUS Spring water not included Without MEC processing	Screw shape	M5X45 SUS Spring water not included Without MEC processing
	Nitta model No.	GSSH05045S+GWSP05S	Nitta model No.	GSSH05045S+GWSP05S
	Torque	5Nm	Torque	5Nm
Remarks		Remarks		
Hydraulic Hydraulic/pneumatic	R side		T side	
	Screw shape	M5X55 SUS With MEC processing (low strength 222)	Screw shape	M5 shoulder bolts SUS With MEC processing (low strength 222)
	Nitta model No.	GSSH05055SM	Nitta model No.	GSHL5254S
	Torque	10Nm	Torque	2Nm
Remarks	Embedded screw	Remarks	This affects floating *2	
Pneumatic	R side		T side	
	Screw shape	M5X40 SUS Spring washer With MEC processing (low strength 222)	Screw shape	M5X40 SUS Spring washer With MEC processing (low strength 222)
	Nitta model No.	GSSH05040S	Nitta model No.	GSSH05040S
	Torque	10Nm	Torque	10Nm
Remarks	Embedded screw	Remarks	Embedded screw	

\*1. Apply screw locking agent (low strength) to each bolt. Locking agent is not necessary for bolts supplied with the product as they are MEC-processed (green MEC; low strength).

### CAUTION

Tightening bolts with torque above the specified torque level may damage threads on the ATC side and modules.  
Further, tightening bolts with torque below the specified torque level or failure to use the locking agent may cause bolts to be loosened, leading to module fall off.

\*2

### CAUTION

Tightening the shoulder bolt with torque above the specified torque level may impair the floating function and damage the module.

### 5-7-1. Wiring for Spot Welding Module (Seal Connector Specifications)

Use cables of compatible cable profiles indicated in each module drawing.

Ex:

- "HBR-023-00": 30-38mm<sup>2</sup>(SQ)
- 22mm<sup>2</sup> (SQ) is supported when a sleeve "HBR-031-00" is used
- "GLUGR8-6": 8mm<sup>2</sup>(SQ)
- "GLUGR14-6": 14mm<sup>2</sup>(SQ)
- "GLUGR22SQ6": 22mm<sup>2</sup>(SQ)
- "CBR-01C-01": 14-22mm<sup>2</sup>(SQ)

**⚠ WARNING** Wrong positioning of the earth may cause electric shock or device damage.

For wiring arrangement, follow the module drawing.

For wiring, follow the procedure below.

#### 1) Cable preparation

- (1) Remove the cable coating so as to make it L-lag (a) + 2mm.

(See Fig. 8)

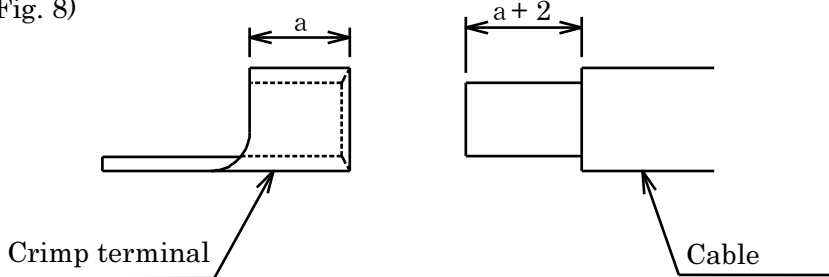

Cable coating must be cut off regardless of whether L-type or crimp

Fig. 8. Cable coating

- (2) Cut each core, with care not to make any twisting or crossing.

At this point, let the cable through the module and check that its length is appropriate without any tension, looseness and interference.

Fit the shrinkable tube to the cable and put an L-lag at its end. Then temporarily tighten M8X8 lock screw not to let it off. If a crimp terminal is used, tighten the screw further by a crimper according to the appropriate sectional area of the terminal used. (See Fig. 1, Fig. 2, and Fig. 3.)



Fig. 1



Fig. 2



Fig. 3

Tighten M8X8 set screws to 3Nm using an M5 torque wrench and put a mark on each. Then tighten M5X10 brass screws to 3.5N using a cross-tip torque wrench and check the electrode motion using a press jig. If the motion is good at 3 points, the work is completed. If the motion is not good, loosen the pertinent M8 set screw and M5 screw and make an adjustment. Then apply appropriate torque (Refer to Fig. 7, Fig. 6, Fig. 5, and Fig. 4.)



Fig. 7



Fig. 6

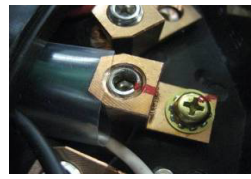

Fig. 5



Fig. 4

After motion confirmation, pull out the shrinkable tube by using longnose pliers and shrink it with a heat gun. (See Fig. 8 and Fig. 9.)



Fig. 8



Fig. 9



**CAUTION**

Replace the shrinkable tube if it is broken.

Cut the signal line (6-core only) into No.4 pin 80mm, No.5 pin 70mm and No.6 pin 110mm from the housing opening, peel the coating off by about 7mm, cut the  $\phi 5$  shrinkable tube into three 20mm pieces and fit them to each cable. (See Fig. 10, Fig. 11, Fig. 12, and Fig. 13.)



Fig. 10



Fig. 11

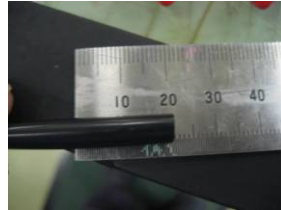

Fig. 12

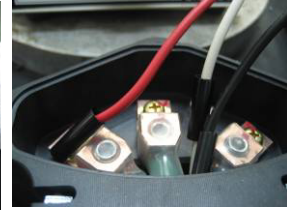

Fig. 13

Impregnate the copper line with flux by using cotton buds or the like. (See Fig. 14 and Fig. 15.)

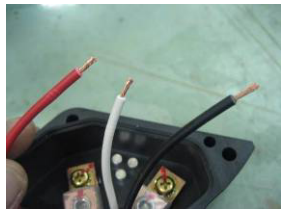

Fig. 14



Fig. 15

2)

Cast solder into 3 signal pin holes in order of No.4, No.5 and then No.6. (See Fig. 16, Fig. 17, and Fig. 18.)

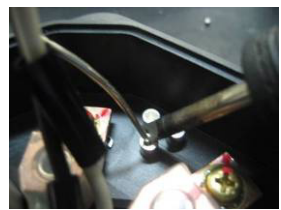

Fig. 16



Fig. 17

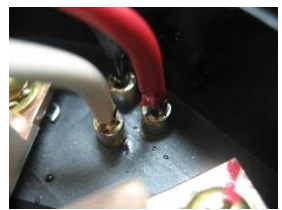

Fig. 18

Fit shrinkable tubes to signal pins and cables. (Refer to Fig. 30.)

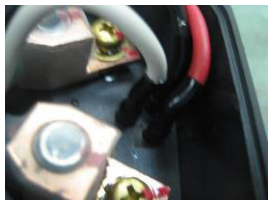
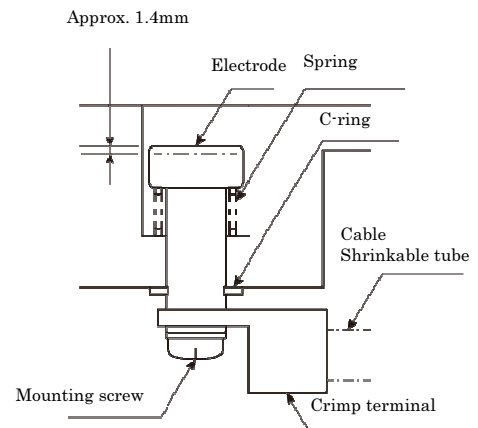

Fig. 19

**⚠ WARNING**

●Precautions for cable connection in case of seal connector spec  
An electrode on a robot side power module can move up and down by approx. 1.4mm. If the cable is pulled during robot operations, the electrode may not work properly resulting in improper power supply and burnout.



**⚠ CAUTION**

Robot side cables must be securely tied together with other cables and tubes and fixed around the robot adaptor's connector part by using a spiral tube or banding band, etc. Also ensure that cables and tubes are free of any excessive force while the robot's wrist axis is rotating. Excessive force applied onto cables and tubes may break a connector of the joint part and an electric module, etc. or cause open-circuit. It may also cause any electric shock hazard and sparking. An example of cable fixing by a bracket is shown in Fig. 9.

**📖 Referenc**

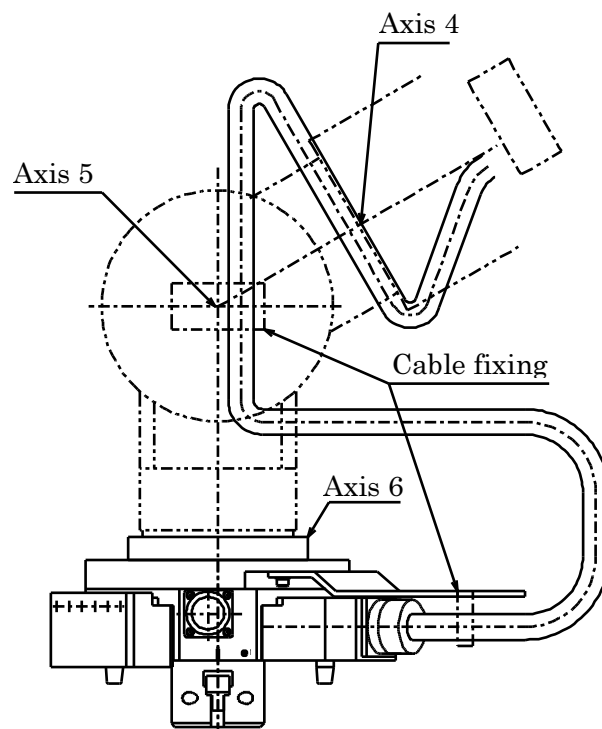

Fig. 9. An example of cable fixing



### 5-7-1. 5-7-2. When a Hydraulic/Pneumatic Module Is Used:

---

**⚠ CAUTION** Ensure no chips of sealing tape on the relay, etc. get into the module. Otherwise, it gets into the O-ring sealing section inside and causes leakage.

---

**⚠ CAUTION** Use SUMIPLEX BN NO.1 (manufactured by Sumico Lubricant) or equivalent grease on the module port surface. Without lubrication, early breakage and leakage may occur.

---

**⚠ CAUTION** It is normal that the tool side hydraulic module has some backlash (floating mechanism). (Mounting: M5 shoulder bolts, 2Nm)  
Leave some allowance in tube connection to secure the floating mechanism. Otherwise, water leakage or hydraulic module damage may occur at the time of coupling. Keep the sealing material not involved in the port. Otherwise, the material trapped in the port may cause water leakage.

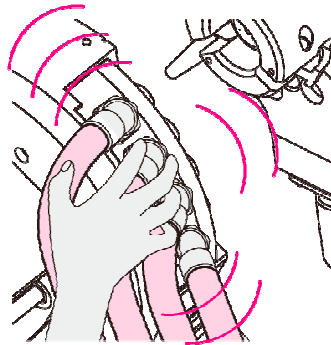

---

**⚠ CAUTION** In case of a non-spill hydraulic module, the grease used for the robot/tool adaptors must not be used. Please use our specified grease, silicone grease SH44 (manufactured by Dow Corning Toray Co., Ltd). Use of other grease will spoil the O-ring due to swelling.

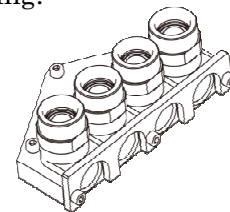

---

**◆ MEMO** If you take measures for water quality management, i.e. using a filter for coolant, change of corrosion within the module is reduced.

---

### 5-7-2. When a Spot Welding/Signal Module Is Used:

---

**⚠ WARNING** Perform wiring as per the delivery specifications. Improper wiring may cause failure or electric leakage, etc.

---

**⚠ WARNING** Securely apply Class III grounding for earth and shield lines. Otherwise, electric shock and noise may occur, leading any malfunctions.

---

## 6. Operations and Programming

### 6-1. Checking before Teaching (Robot Operations)

**⚠ CAUTION**

Ensure that cables and tubes (hereinafter cables, etc.) are routed and fixed to the bracket without breaking. Also, ensure that the cables, etc. are fixed so that they do not interfere with peripheral components and work pieces during robot operations. \*See 5-5. Cable Fixing.

**⚠ CAUTION**

Ensure that grease is applied to the shaded points.  
\*See 5-6-2. ATC Grease Up.

**⚠ CAUTION**

In case of a non-spill hydraulic module, the grease used for the robot/tool adaptors must not be used. Please use our specified grease, silicone grease SH44 (manufactured by Dow Corning Toray Co., Ltd). Use of other grease will spoil the O-ring due to swelling.

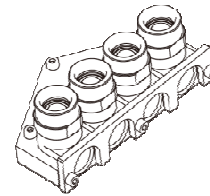

**⚠ WARNING**

- 1) Ensure that air supply is not shut off by bending/twisting of the unchuck tube and excessive tightening of the banding bands. When the air supply is inhibited, the cam may not work properly resulting in tool side module falling.
- 2) Check that the unchuck port air is discharged before coupling (no residual pressure). Any residual pressure may prevent normal cam operations and cause the tool side modules fall off.

1) Tube

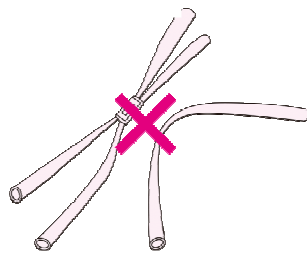

- Tube bending
- Tube twisting
- Excessive tightening of tube with banding band

2) Solenoid valve

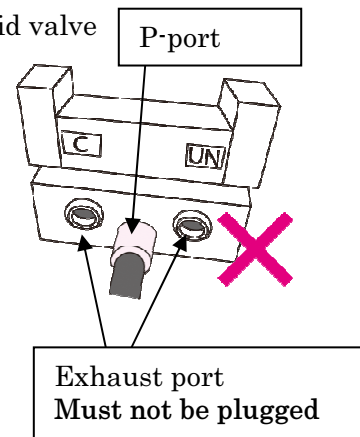

**⚠ WARNING**

When operating a robot with a tool coupled, be sure to supply air to the chuck port.

## 6-2. Operations and Programming

This section describes a simple example of external interlock signals of the ATC. The ATC requires synchronization with a robot and peripheral devices and exchange of operation check signals to ensure reliability and safety.

The ATC has three built-in sensors for detection of its own motions. For details, please refer to "Overview of the Automatic Tool Changer (ATC)."



### WARNING

Configure interlock settings for chuck (\*1), unchuck(\*2), face (\*3) and tool presence signals, etc. of the ATC. Check that the cam opening/closing is properly detected by the three face sensors and the respective LED lamps (\*4) light up accordingly. Check that interlock signals are input to the superior control devices, such as PLC. Without setting of external interlock signals, safety may not be ensured in the event of operator errors or malfunction, posing a risk of tool falling.

\*1. Chuck signal: Indicates that cam is opened

\*2. Unchuck signal: Indicates that cam is closed

\*3. Face signal: Indicates that coupling planes of the robot adaptor and tool adaptor are closely mated together

\*4. LED lamps: Light up in different patterns to indicate the above signal output patterns

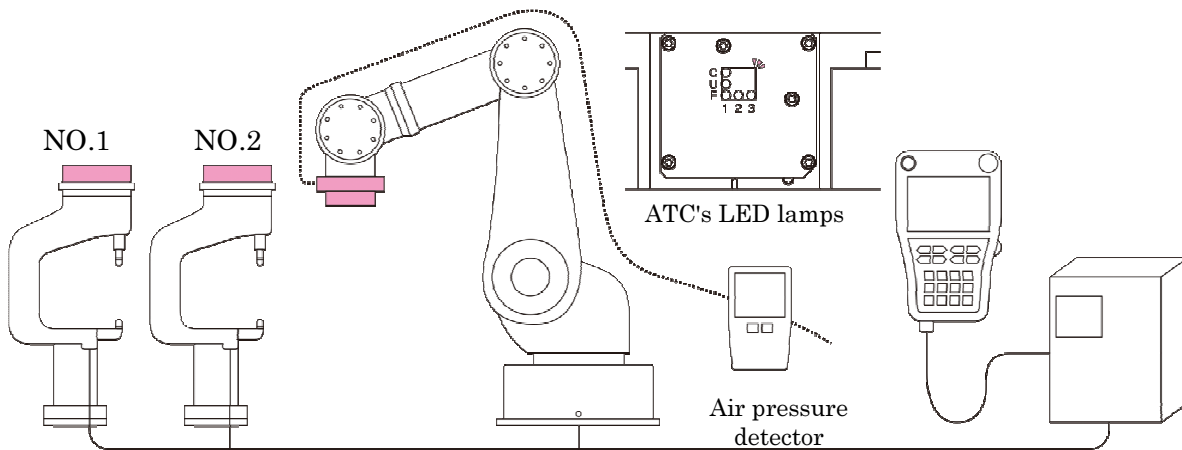

- |  |  |
|--|--|
| <p>(1) Tool presence check</p> <p>(2) Each tool NO. identification check</p> | <p>(3) ATC internal signal check (face, chuck, and unchuck) LED lamp normal ON check</p> <p>(4) Check of detected decrease in air pressure for ATC driving</p> |
|--|--|

Fig. 10. Example of interlock

- The illustration above shows an example interlocking scheme for your reference. Please design safe interlocking scheme appropriate for your facilities.
- We offer specs with fall-protection mechanical valve or safety switch. (For details, please feel free to contact us.)
- If you do not choose to have our fall-protection mechanical valve or safety switch, be sure to introduce an appropriate safety system separately.

### 6-3. Basic Flow of ATC

Ensure the robot interlock with reference to the flow indicated in Chart 2.



Chart 2. Basic flow of ATC

Robot motion		Input			Robot Output		External input	LED Output		
		Chucking Sensor			Controlling		Fixture Limit	LED ASSY		
		Face	Chuck	Unchuk	Chuk	Unchuck	Tool side	Face	Chuck	Unchuk
CHUCKING	Waiting position	OFF	OFF	ON	OFF	ON	ON	OFF	OFF	ON
	↓	↓	↓	↓	↓	↓	↓	↓	↓	↓
	Moving	↓	↓	↓	↓	↓	↓	↓	↓	↓
	↓	↓	↓	↓	↓	↓	↓	↓	↓	↓
	Near by chucking position	↓	↓	↓	↓	↓	↓	↓	↓	↓
	↓	↓	↓	↓	↓	↓	↓	↓	↓	↓
	Approaching	↓	↓	↓	↓	↓	↓	↓	↓	↓
	↓	↓	↓	↓	↓	↓	↓	↓	↓	↓
	Chucking position	ON	↓	↓	↓	↓	↓	ON	↓	↓
↓	↓	↓	↓	↓	↓	↓	↓	↓	↓	
Chuck	↓	ON	OFF	ON	OFF	↓	↓	ON	OFF	
↓	↓	↓	↓	↓	↓	↓	↓	↓	↓	
Chucking completion	↓	↓	↓	↓	↓	↓	↓	↓	↓	
↓	↓	↓	↓	↓	↓	↓	↓	↓	↓	
Moving	↓	↓	↓	↓	↓	OFF	↓	↓	↓	
↓	↓	↓	↓	↓	↓	↓	↓	↓	↓	
Working	↓	↓	↓	↓	↓	↓	↓	↓	↓	
UNCHUCKING	Working	ON	ON	OFF	ON	OFF	OFF	ON	ON	OFF
	↓	↓	↓	↓	↓	↓	↓	↓	↓	↓
	Moving	↓	↓	↓	↓	↓	↓	↓	↓	↓
	↓	↓	↓	↓	↓	↓	↓	↓	↓	↓
	Unchuck position	↓	↓	↓	↓	↓	ON	↓	↓	↓
	↓	↓	↓	↓	↓	↓	↓	↓	↓	↓
	Unchuck	↓	OFF	ON	OFF	ON	↓	↓	OFF	ON
	↓	↓	↓	↓	↓	↓	↓	↓	↓	↓
	Leaving	OFF	↓	↓	↓	↓	↓	OFF	↓	↓
↓	↓	↓	↓	↓	↓	↓	↓	↓	↓	
Near by unchucking position	↓	↓	↓	↓	↓	↓	↓	↓	↓	
↓	↓	↓	↓	↓	↓	↓	↓	↓	↓	
Moving	↓	↓	↓	↓	↓	↓	↓	↓	↓	
↓	↓	↓	↓	↓	↓	↓	↓	↓	↓	
Waiting	↓	↓	↓	↓	↓	↓	↓	↓	↓	

represents process stepping conditions.

- "ATC coupling check end ON" should be active during robot operations (during production).



**WARNING** Continuous signaling is recommended for solenoid valves for chuck/unchuck. Please do not use one-shot signaling because it may not maintain the chuck status due to malfunction caused by any noise resulting in module falling.

## 6-4. Interlocking around ATC

For safe and smooth operations of ATC, it is recommended to configure the following signals.

- 1) Signal of detection of decreased air pressure for ATC driving  
This signal notifies a robot of reduction of ATC driving air pressure for any reason, and robot operations will be halted when this signal is turned OFF.
- 2) Tool side presence signal  
This signal detects the tool side unit of ATC (material handling equipment, etc.) is on the tool stand. This is an interlock signal to provide unchuck valve ON output, check that the ATC is securely located on the tool stand, and proceed with next robot step while checking that the entire tool side unit of the ATC is on the tool stand. This prevents the tool from falling in any unexpected situation.



### **WARNING**

---

The tool presence signal is a very important interlock signal to tell the ATC can be detached safely.

Failure to use the tool presence signal as an interlock signal may cause the tool fall off during manual operations, leading to an unexpected accident.

---

- 3) Tool No. check signal  
This signal is used by the ATC to check consistency between a coupled tool and running program No. when, for example, multiple robots are coupled with a tool from the same tool stand.
- 4) ATC operation check signal indicators  
It is recommended to install indicators that constantly shows ON/OFF states of the aforementioned three signals (chuck end, unchuck end, and coupling check end signals) indicating the ATC operation status, and user signals used with the ATC (e.g. tool clamp end work presence).  
This allows to readily comprehend any signal-related trouble and interlock waiting status.

## 6-5. Precautions for Operations

- ⚠ CAUTION** Basically, the connecting surfaces of the robot adaptor and tool adaptor must be in parallel during the ATC chuck/unchuck operation. Otherwise, proper chuck and smooth unchuck may be prevented. Moreover, the electric contacts and hydraulic/pneumatic ports may be spoiled earlier. If it is not possible to maintain parallelism with the robot and the tool stand, the tool stand must have an alignment function. On a tool stand with an alignment function, mate the flat planes by pressing the robot adaptor against the tool adaptor for proper teaching. (The alignment function must be designed to compensate for robot thrust, tool weight, flatness, and center deviation.)
- Also, in the unchuck process, the tool adaptor may lean and cause prying due to reaction force of ATC's electric contact and pneumatic port, preventing unchuck. In such cases, the robot adaptor must be pressed against the tool adaptor as in the coupling process to prevent the tool adaptor from moving (deviating and leaning) right after unchuck. At this point, the tool must remain on the tool stand. Then, perform teaching so that the built-in sensors can detect unchuck and ensure smooth evacuation without prying.
- We offer teaching jigs. If you are interested in using them, please feel free to contact us.

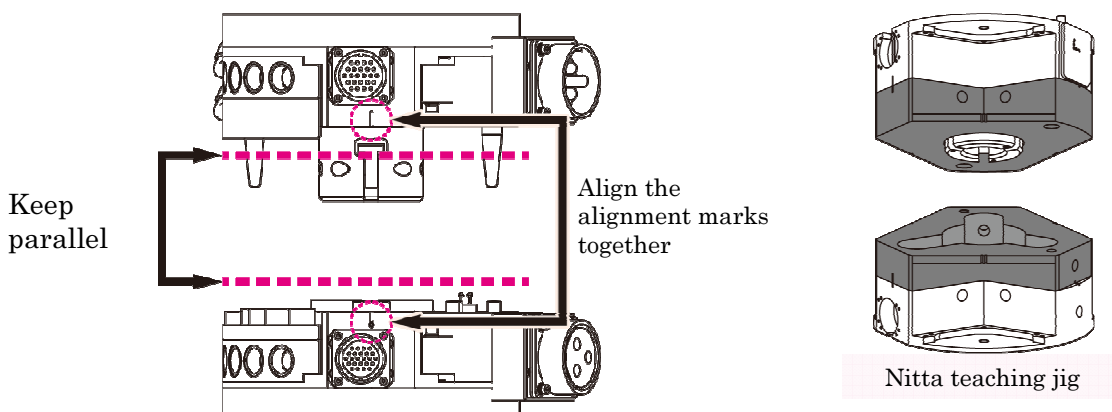

Fig. 11. Precautions for teaching

- ◆ MEMO** For the above, it is recommended to place ATC's tool stand on the level. However, if it needs to be upright due to a space constraint, please consider the following.

- 1) There must be no backlash of the tool adaptor's tool stand (besides the alignment function).
- 2) It must not move due to tool's offset load during unchuck or chuck of the tool adaptor. (As far as possible, it should be supported near the tool adaptor.)
- 3) It must be pressed with sufficient pressure for coupling with the tool adaptor and have sufficient rigidity to prevent deflection of the tool stand. Also the anchor bolts must not be loosened or come off.
- 4) Tool side supports and tool side supported positioning sections of the tool stand must be abrasion resistant. It is desirable that parts can be replaced.

---

**⚠ WARNING**

Do not separate the robot adaptor carelessly when the tool adaptor is not in its home position on the tool stand.

Separating the tool adaptor while not in its home position may damage the ATC or peripheral equipment and/or hurt operators.

---

If the ATC is applied for demurring or other machining, position the tool stand so that no cutting chips and cutting oil are adhered to the tool adaptor.

If the stand position is exposed to adverse environment with spatters, water drops and dust particles, install an automatic cover (Nitta Change Cover) or the like to protect the tool adaptor. Further, in oily atmosphere, ensure good conduction by, for example, air blow on the signal pin section.

We offer standardized peripheral devices for the ATC such as fall-protection system. For details, please feel free to contact us.

## 6-6. Points to Check during Line Downtime (or Line Uptime)

### ⚠ WARNING

- Recommended usage

During the robot downtime, e.g. nighttime or holidays, keep the tool side module detached. During uptime, check that the cam is closed at the time of approaching for coupling of the tool side unit. Coupling operations performed with cam left opened may cause crash between the cam and lock pin, resulting in component damage.

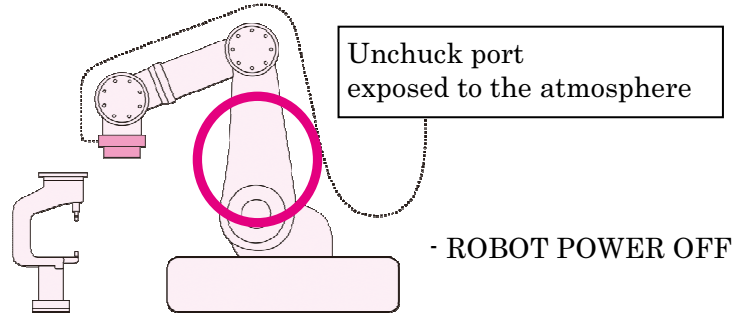

Fig. 12. Precautions for Line Downtime

### ⚠ DANGER

- Usage not recommended (only allowed if there is an absolute necessity)

If the tool side adaptor cannot be kept detached during downtime due to any reasons related to the facilities, take due care of the following.

If the line has to be stopped with the tool side module coupled, be sure to release the unchuck port regardless of air supply pressure presence. (No residual pressure allowed.)

If the unchuck port is not released, the cam may be operated due to air wraparound resulting in tool side module falling. Position the tool appropriately to prevent falling and turn the power and air supply OFF before stopping the equipment.

There may be residual air pressure when:

- air supply is shut off by bending/twisting of the unchuck tube or excessive tightening of the banding bands (see 6-1 in page 33); or
- the exhaust ports of the manifold and solenoid valve are plugged (see 6-1. in page 33).

Points to check before restarting the line:

- Ensure there is no gap between the coupling planes.

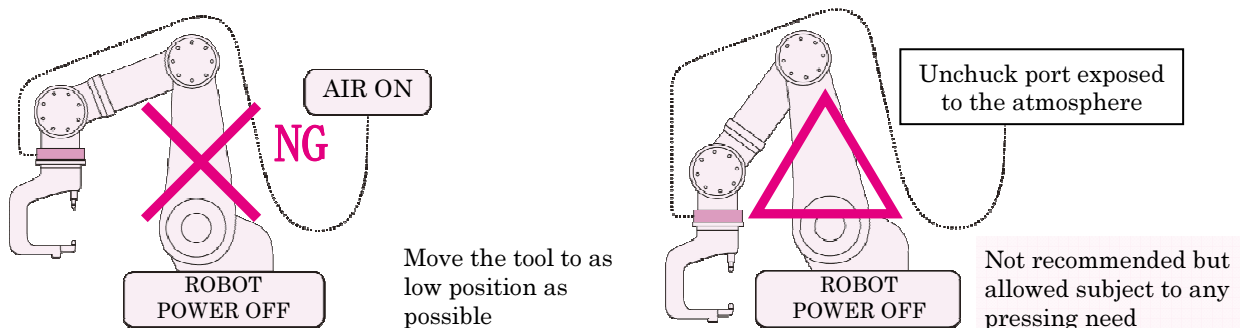

Fig. 13. Positions that should be avoided during line downtime



## 6-7. Emergency Response Actions

### 6-7-1. Manual Unchuck in Case of Emergency

The ATC has holes on the tool adaptor side to fold the cam toward the unchuck side. For manual unchuck, ensure that the tool will not fall off during the unchuck process.

**⚠ DANGER**

**Fall protection with sufficient strength must be implemented.**

(For example, suspend the gun with a rope.)

- (1) Check that the air pressure is applied to the "UNCHUCK" port.
- (2) Insert a screwdriver into a hole for manual separation and move the cam backward.

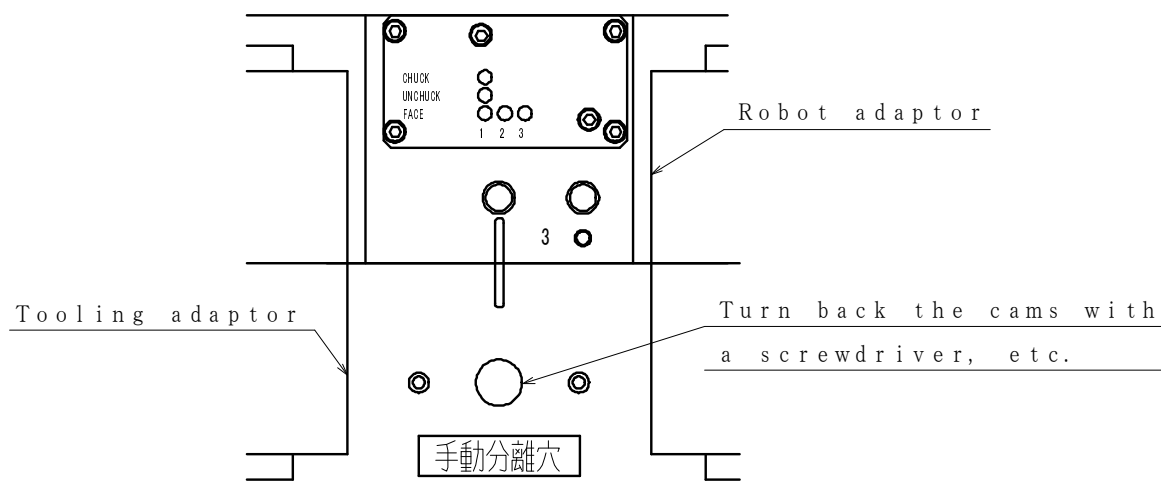

Fig. 14. Forced separation

### 6-7-2. Response Actions to Interference or Crash

#### CAUTION

In the event of interference or crash with a robot or a jig attached to the robot (e.g. gun and transformer, etc.), be sure to take the inspection and response actions described in Chart 3. A significant force is applied to ATC upon interference or crash, which may create any factor that shorten the product service life. Therefore, the inspection interval may need to be shortened as necessary. For ATC replacement and damaged part replacement, please refer to relevant sections of this document and the "Maintenance Procedures."

Chart 3. Response actions to interference or crash

	Check item	Check method	Response action to abnormality
1	Presence/absence of cracking	Visual	ATC replacement
2	Housing deformation	Visual	ATC replacement
3	Loose bolts	Mounting bolts	Re-tightening
4	Cam chuck/unchuck operations and signal system check	Turn the valve ON/OFF manually and check operations and signal ON/OFF.	ATC replacement
5	Presence/absence of gap of coupling planes	Visual: Cam surface damage; lock pin and pivot pin breakage and damage; and mating surface dent	Replacement of damaged parts
6	Presence/absence of rattle in the rotation direction	Visual: Tapered pin breakage; bush damage; and loose bolts	Replacement of damaged parts
7	Check for damage in electric signal pins and connector cables, etc.	Visual, and I/O panel signal check	ATC replacement and replacement of damaged parts

### 6-7-3. Response Action to Water Exposure

#### CAUTION

If the equipment is exposed with water, immediately stop using it and check if water enters into the product. Using the equipment with water presenting in internal electric component may cause signal output failure due to short-circuit. Moreover, when grease is washed out by water, sliding parts will be subject to higher friction, which can result in poor coupling or sealing. In the event of exposure to water, be sure to conduct the inspection and actions specified in Chart 4.

Chart 4. Response action to water exposure

	Check item	Check method	Action
1	Electric contact and proximity SW signal	Check for short-circuit on the I/O unit side. Visually check for malfunction of the chuck/unchuck sensor and LED ASSY, and ensure there is no water infiltration.	If any, wipe off with a dry cloth. (*Do not attempt to blow water off with an air gun or the like as doing so may let water get further into the equipment.)
2	Cam, lock pin and tapered pin	Visual check	Apply grease.
3	O-ring	Visual check	Apply grease.
4	Other section exposed with water	Check all sections for water accumulation and wipe off if any.	Apply grease to uncoated metal parts.

#### 6-7-4. Precautions for Transportation

**⚠ WARNING**

---

To move the system with the modules coupled together without air supply, use rope or the like to bind them and prevent tool side module from falling.

---

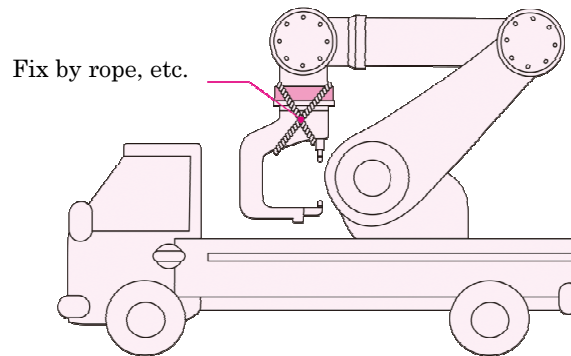

Fig. 15. Precautions for transportation

