

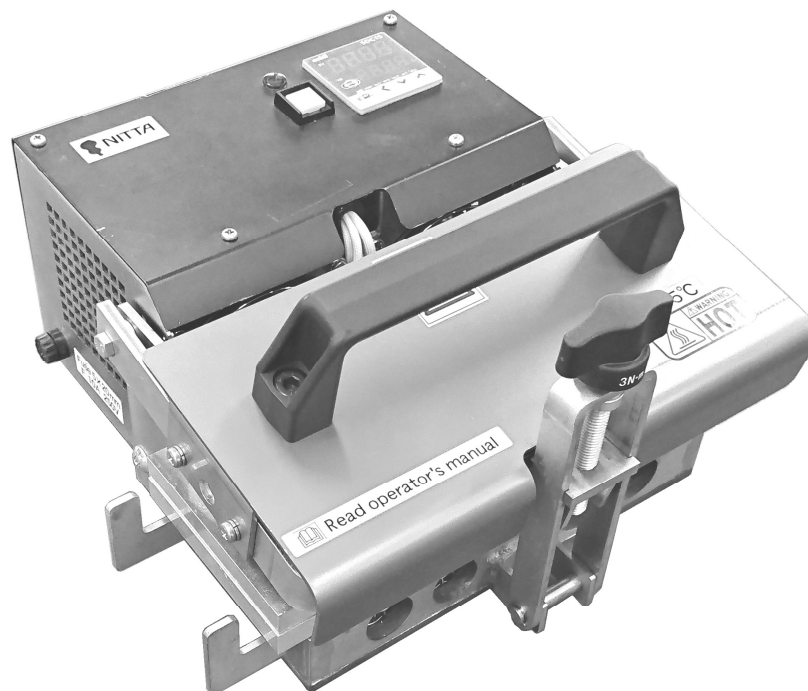

Integral Heating and Cooling Press

NPS-2005A-1/2

OPERATOR'S MANUAL



-  Thoroughly read this operator's manual before operating the press.
-  To use endless splicing tools safely, be sure to hand this manual to the operator or worker.

NITTA CORPORATION

Table of Contents

1. Safety Precautions	2
2. Confirmation of Product	6
3. Specification	7
4. Operation Environment	8
5. Storage Environment	8
6. Name of each Parts	9
7. Operation Procedure	11
8. Endless Splicing Procedure	13
9. Troubleshooting	17
10. Inspection	18
11. Maintenance	19
12. Warranty and after-sales service	20

1. Safety Precautions

We would like to thank you for having purchased our Integral Heating and Cooling Press **NPS-2005A**

Thoroughly read this manual, especially the chapter on Safety Precautions, to use this machine safely.



This indicates a hazardous situation which, if improperly handled, will result in death or serious injury.



This indicates a potentially hazardous situation which, if improperly handled, will result in minor injury or property damage.

WARNING



Do not use this machine for any use other than belt endless splicing. Any use not intended for the prescribed purpose may invite an unexpected accident.
Improper use may render ineffective the safety protection features of the product.



This machine is not intended for use by the physically, sensory or mentally handicapped. They must have the supervision of a person responsible for their safety, if they use this machine.
Failure to do this may cause fire, electric shock or injury.



Do not allow children to handle this machine. Keep this machine out of reach of children.
Failure to do this may cause fire, electric shock or injury.



A person with technical knowledge and skills should always operate, maintain and inspect this machine.
Handling by a person not having technical knowledge may cause fire, electric shock or injury.



Strictly avoid disassembling or remodeling this machine.
Disassembling or remodeling this machine may cause fire or electric shock.
When repair or check is required, please contact your local distributor, agent in your area or our company.



In the event of trouble (smoke, fire or nasty smell, etc.), please immediately disconnect the power plug and contact your local distributor, agent in you area or our company for inspection or repair.
Failure to do this may cause fire or electric shock.



When not using or carrying this machine, be sure to set the hook and turn the torque limiter until it slips to securely clamp the heat plate.
Failure to do this may cause injury.



WARNING

Confirm that the power supply to be used is within the designated of specification for this machine.

Failure to do this may cause fire or electric shock.

Model	Power supply
NPS-2005A-1	100 - 120V 50 / 60Hz
NPS-2005A-2	200 - 240V 50 / 60Hz



WARNING

Avoid using the press in the following environment.

Failure to do this may cause fire or electric shock.

- In an atmosphere of inflammable or ignitable gas
- In an atmosphere of corrosive gas
- In ambient temperature of 5°C or below
- In ambient temperature of 40°C or above
- In an atmosphere of high humidity (environment where humidity exceeds 85%)
- In an environment subject to wet conditions from steam, water droplets or dew condensation, etc.



WARNING

Be sure to wear heat-resistant gloves when operating this press.

Failure to do this may cause burns.



WARNING

When operating this press, avoid touching the heat plate area even if wearing heat-resistant gloves.

Failure to do this may cause burns, even if wearing heat-resistant gloves, since press heat plates get heated to the press's preset temperature once the press is plugged in.



WARNING

Avoid operating the press at the place close to combustible material.

Failure to do this may cause fire.



WARNING

Always use the pre-setter designed for this product.

Failure to do this may cause fire or electric shock.

Use of a pre-setter made for other products or by another manufacturer may render ineffective the safety protection features of the product.



WARNING

Use a dry cloth for cleaning this machine. Strictly avoid using alcohol, benzene, thinner or other inflammable solvents.

Using inflammable solvents may cause fire.



WARNING

Impressed voltage is directly applied to the power cable. Observe the following precautions not to damage the cable.

Failure to do this may cause fire or electric shock.

- Disconnect the power plug by hand.
- Avoid pulling the cable to disconnect the power plug.
- Avoid modifying the power plug or replacing the plug with one from another manufacturer.
- Avoid placing anything on the power cable.
- Avoid bending the power cable.
- Take care to prevent the power cable from touching the heat plate of the press.



WARNING

Connect the power plug to the socket correctly.

Failure to do this may cause electric shock.



The power cable of this machine uses a grounded connection plug. Connect the power plug correctly into a grounded connection socket.



Use a conversion plug when the plug shape does not match the socket.

Failure to do this may cause electric shock.

The plug shape of the attached power cable is as follows. The conversion plug is not attached. When a conversion plug is necessary, users must provide their own.

Model	Plug type	Plug illustration
NPS-2005A-1	A Type	
NPS-2005A-2	CEE7 (S Type)	



Never handle this machine or the plug, cable, etc. with wet hands.

Failure to do this may cause electric shock..



Never use this machine if it is wet.

Failure to do this may cause electric shock or fire..

CAUTION



Exercise care not to pinch your hands between the top cover and control box or the upper and lower heat plates.

Failure to do this may cause injury.

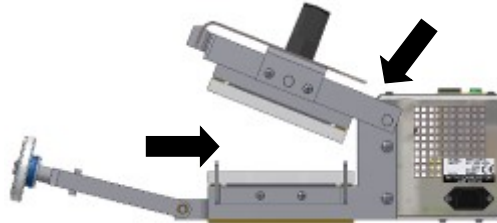

Avoid inserting your hands into the opening on the front face of the press.

Failure to do this may cause burns..

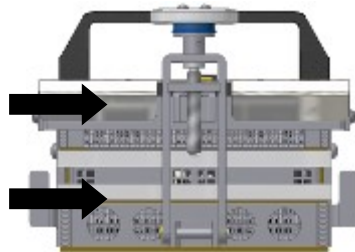

Avoid using this machine outdoors.

This product is not intended for the use outdoors.



Avoid dropping this machine or giving it a strong jolt.

Failure to do this may cause fire or electric shock.



Take measures to prevent this machine from dropping or falling, and do not install or operate the press in an unstable location.

Failure to do this may cause injury, fire or electric shock.



Carry out the inspection described on page 18 of this manual before operating this machine.

Failure to do this may cause fire or electric shock.



Do not use this machine for the endless splicing of belt of other manufacturers.

Splice defects may occur if this machine is used for endless splicing of belts from other manufacturers.

This may reduce the function and performance of the belt, or render it unusable.

2. Confirmation of Product



Before operating the press, check that the product is exactly what you have ordered. Using this product other than those specified in this manual may cause fire, electric shock, injury or burn.

2-1) Confirmation of Product

On opening the package, confirm the following points.

- 1) Are descriptions on the nameplate the same as those of item ordered?
Confirm the model and power supply specification.
- 2) Is there any breakage or anything missing?
The package contains this manual, the press and power cable.
- 3) Have screws and nuts loosened during shipping?

We double-check all items during inspection and shipment of products. In the event of any defect or failure, please contact your local distributor, agent in your area or our company.

2-2) Confirmation of the nameplate

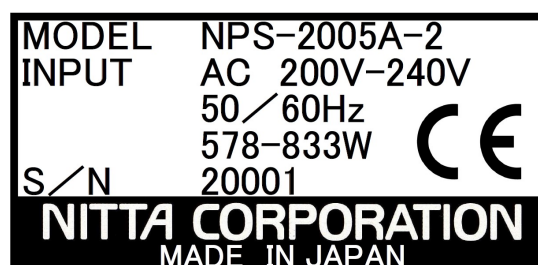
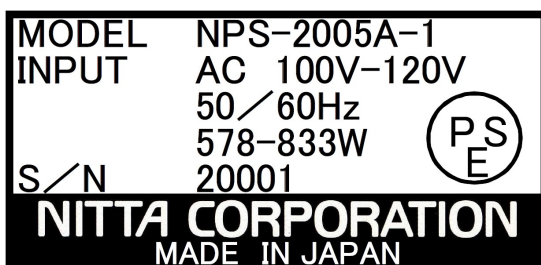

MODEL: Press model
INPUT: Input power supply specification and power consumption
S/N: Serial number

2-3) Press model

There are two kinds of models with a different input power supply. The specification of the power supply is described by the input.

2-4) Notes for inquiry

When making inquiries, please contact us with both the press model and serial number.

3. Specification

3-1) Outline of the press

- (1) The NPS-2005A press is specially designed for the joining of NITTA's CFTG belts using 200mm long "fingers."
- (2) This machine is applicable with the following belt endless splicing specifications.
 Joint specification: Finger shape: 200 mm long × 10 mm pitch
 Maximum belt width: 60 mm or less
 Maximum belt thickness: 7.5mm or less
- (3) Finger-endless splicing requires the finger puncher and pre-setter* of another-sales.
The pre-setter is required for each width belt that is to be made endless-spliced.

3-2) Main specifications of the Press

Model	NPS-2005A-1	NPS-2005A-2
Input power supply	100 - 120V	200 - 240V
	50 / 60Hz	50 / 60Hz
	578 - 833W	578 - 833W
Fuse	φ5.2 × 20mm 10A, 250V*	
Preset temperature	45 - 200°C**	
Outer dimension	With the press closed: 301 mm wide × 300 mm long × 180 mm high With the press opened: 301 mm wide × 440 mm long × 266 mm high	
Weight	8.2 kg	

* When replacing the fuse, use the article of the specification shown above.

** Cannot set outside the range of the preset temperature (44°C or lower, 201°C or higher).

This machine has been set to end cooling at 45°C of temperature. Hence setting the temperature to around 45°C may cause this machine to go standby without operating the cooling fan.

4. Operation Environment

Ambient temperature	5 – 40°C (no dew condensation)
Ambient humidity	15 – 85%R.H.
Working place	Indoor (place without dust and water)
Atmosphere	No inflammable, combustible or corrosive gas and steam



Avoid using this machine in the following environment.

Failure to do this may cause fire or electric shock.

- In the environment of inflammable or combustible gas
- In the environment of corrosive gas
- In the ambient temperature of 5°C or below
- In the ambient temperature of 40°C or above
- In the environment of high humidity (humidity exceeds 85%)
- In the environment of wetting by steam, water drop or dew condensation, etc.

5. Storage Environment

Ambient temperature	5 - 40°C (no dew condensation)
Ambient humidity	15 - 85%R.H.
Working place	Indoor (place without dust and water)
Atmosphere	No inflammable, combustible or corrosive gas and steam



When not in use, store this machine under the above conditions.

Poor storage conditions may cause mechanical disorders in the machine and may result in electric shock or fire.



When not using or carrying the machine, be sure to set the hook and turn the torque limiter until it slips.

Insufficient clamping may cause injury.



Before operating the machine, be sure to conduct the prior-to-use inspection and confirm the normal performance.

In the event any abnormality is found in the prior-to-use check, please immediately contact your local distributor, agent in your area or our company.

6. Name of each Part

6-1) Left side view of the press

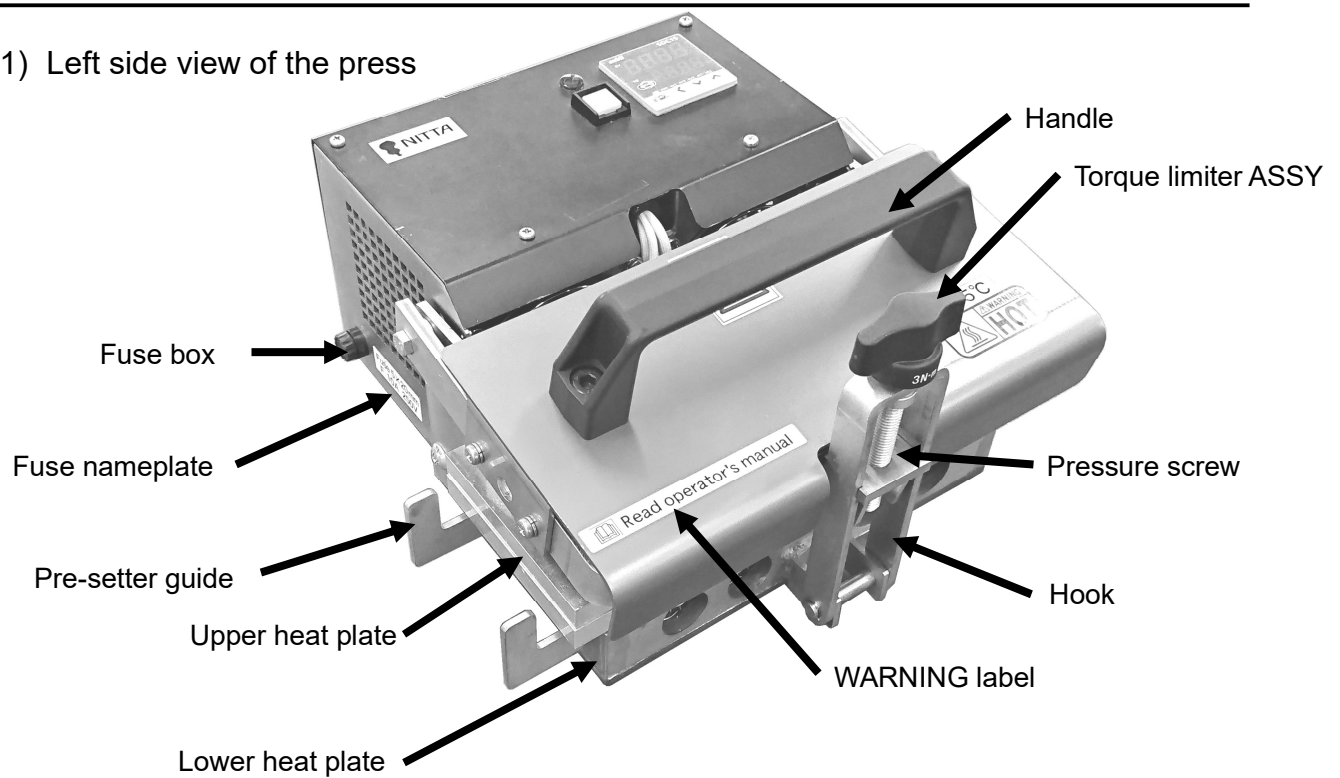

6-2) Right side view of the press

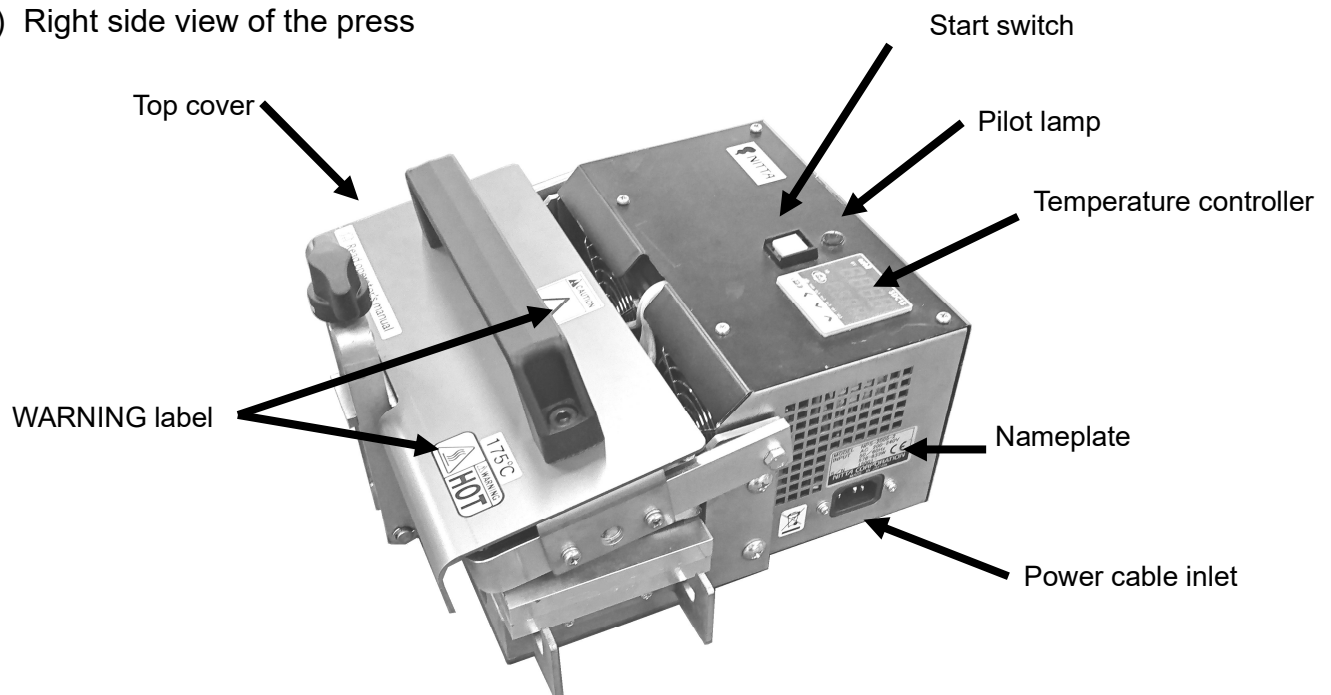

6-3) Temperature controller

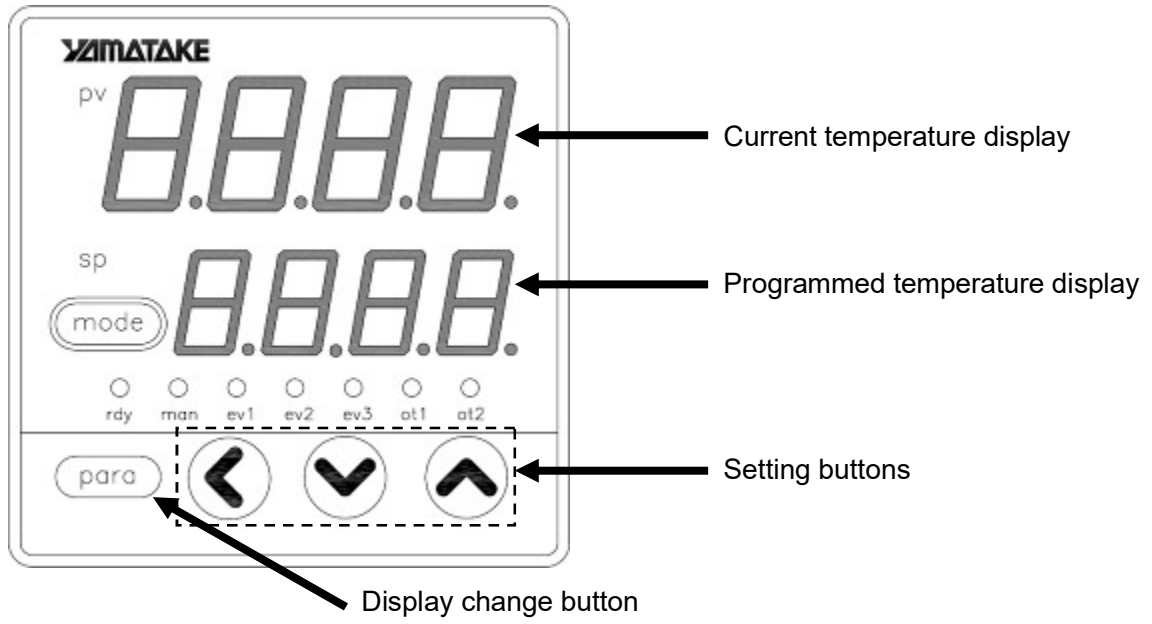

7. Operation Procedure

7-1) Power ON

Connect the power plug to the socket correctly.

The power is supplied to the temperature controller. The controller indicates the present temperature (upper display) and preset temperature (lower display).



WARNING Be sure to connect to a grounded outlet.

7-2) Temperature setting (Temperature controller)

- 1) Check that the pilot lamp is off (no heating or cooling).
- 2) Push the (para) display change button three times to indicate "SP-1" on the present temperature display. At this time, the preset temperature display indicates the preset temperature.

*** The preset temperature before shipping is 185°C.**

- 3) Push the (▲) (up) button to raise the preset temperature or push the (▼) (down) button to lower. Push the button once and the flickering figure increase or decrease 1°C each time.
Pushing the (◀) (side) button shifts the figure of temperature.
- 4) The figure of the preset temperature display is flickering when the figure of the temperature is adjusting.
The preset temperature will be fixed when no pushing is made for 2 sec or more.
- 5) Push the (para) display change button two times to return the present temperature display to the original state.

7-3) Hold time setting (Temperature controller)

- 1) Check that the pilot lamp is off (no heating or cooling).
- 2) Push the (para) display change button four times to indicate "E1.on" on the present temperature display. At this time, the preset temperature display indicates the hold time (in sec).

*** The hold time before shipping is 300 sec.**

- 3) Push the (▲) (up) button to increase the time or push the (▼) (down) button to decrease. Push the button once and the flickering figure increase or decrease 1 sec each time.
Pushing the (◀) (side) button shift the figure of hold time setting.
- 4) The figure of the hold time display is flickering when the figure of the hold time is adjusting.
The hold time setting will be fixed when no pushing is made for 2 sec or more.
- 5) Push the (para) display change button once to return the present temperature display to the original state.
The indicator of temperature returns to the preset temperature.



CAUTION

Although changing the preset temperature and hold time is possible also during heating or cooling, heating or cooling may become incorrect. Hence avoid changing the setting during heating or cooling since it may cause incorrect endless splicing.

7-4) Operation

- 1) To start operation, push the start switch for 0.5 sec or more.
- 2) On starting of operation, the pilot lamp lights and the heating of upper and lower heat plates start.
- 3) The machine operates in the sequence of; heating to the preset temperature, temperature holding (period previously set) and cooling. On completion of temperature holding, the pilot lamp goes off, and the machine operate the cooling fan until present temperature goes below 45°C.
- 4) When present temperature goes below 45°C, the cooling fan stops and the machine become a standby.



WARNING

Be sure to wear heat-resistant gloves when operating the press.

Failure to do this may cause burn.



WARNING

An operator should not leave the machine in use. Take a measure to prevent other people from touching this machine unexpectedly.

Failure to do this may cause burn on other people.

7-5) Discontinuing operation of the machine while in use

Disconnect the plug if it becomes necessary to discontinue operation of the machine while it is in use.

*** Even if the plug is disconnected during operation, preset data of preset temperature and hold time are maintained.**



WARNING

When operation is discontinued during use, the machine is kept at high temperature. Be sure to wear heat-resistant gloves when handling the machine.

Failure to do this may cause burns.



WARNING

The operator should take measures to prevent other people from touching the machine accidentally, until the machine temperature lowers to near room temperature (about two hours).

Failure to do this may cause burns to others.



CAUTION

If machine operation is discontinued during the process of splicing a belt, do not use the belt.

The splice may become defective, reducing the function and performance of the belt, or rendering it unusable.

8. Endless Splicing Procedure

8-1) Required Tool

Figure/Photo	Description
<p>Fig. a</p> <p>Fig. b</p> <p>Fig. c</p>	<p>Fig. a Integral Heating and Cooling Press [NPS-2005A-1/2]</p> <p>Fig. b Heat resistant gloves (burn-preventive protection kits) This item is not contained in the product package. The user must prepare gloves yourself.</p> <p>Fig. c Pre-setter This item is not contained in the product package. The pre-setter is required for each width belt.</p> <div style="border: 1px solid black; padding: 5px; display: inline-block;">  WARNING </div> <p>This machine reaches a high temperature. Be sure to prepare heat-resistant gloves and wear it. Failure to do this may cause burn.</p>

8-2) Belt setting

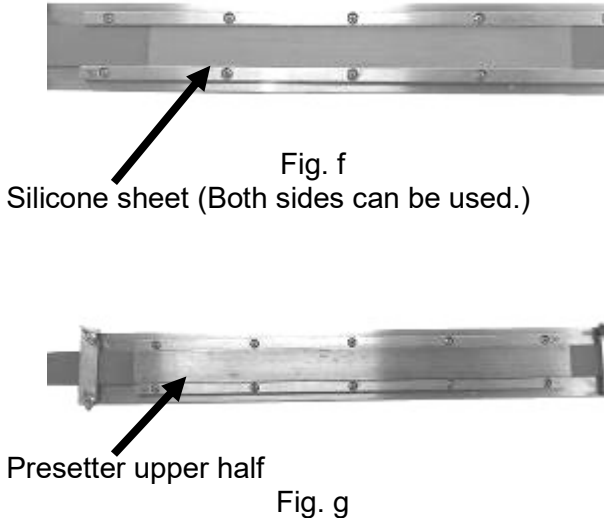

Figure/Photo	Description
<p>Fig. d</p> <p>Fig. e</p>	<ol style="list-style-type: none"> Set both ends of the belt punched into finger shape beforehand on the lower pre-setter as shown in Fig. d. <ul style="list-style-type: none"> * Exercise care not to twisting on the way of belt. * Confirm the front side and the back side of belt before setting. Refer to the attached endless condition table. <div style="border: 1px solid black; padding: 5px; display: inline-block;">  WARNING </div> <p>Always use the pre-setter of our product. Use of any other product possibly results in an improper endless joint and may cause fire.</p> <ol style="list-style-type: none"> Set the belt by mating finger joints leaving no gap so that the joint part is located within marking lines on the pre-setter as shown in Fig. e.

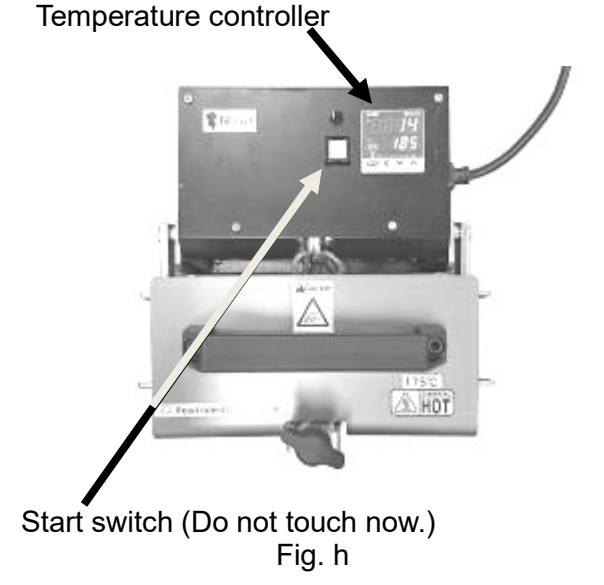

Figure/Photo	Description
 <p>Fig. f Silicone sheet (Both sides can be used.)</p> <p>Fig. g Presetter upper half</p>	<p>3) Set the silicone sheet on the belt as shown in Fig. f.</p> <ul style="list-style-type: none"> * Remove any dust or foreign object on the silicon sheet before operation. * Change the sheet if deteriorated, scratched or torn. <p>4) Place the upper pre-setter over the silicone sheet as shown in Fig. g.</p> <ul style="list-style-type: none"> * The upper pre-setter has also marking lines. Place the upper pre-setter over the lower one while mating the marking lines.

8-3) Preparation of press

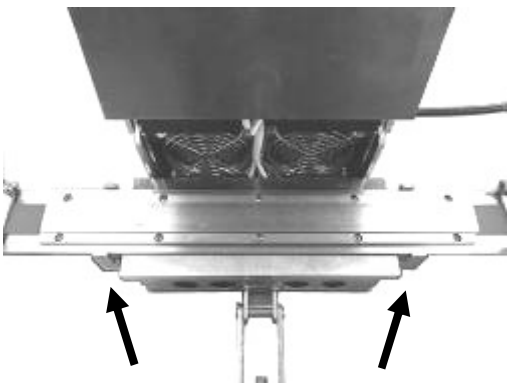
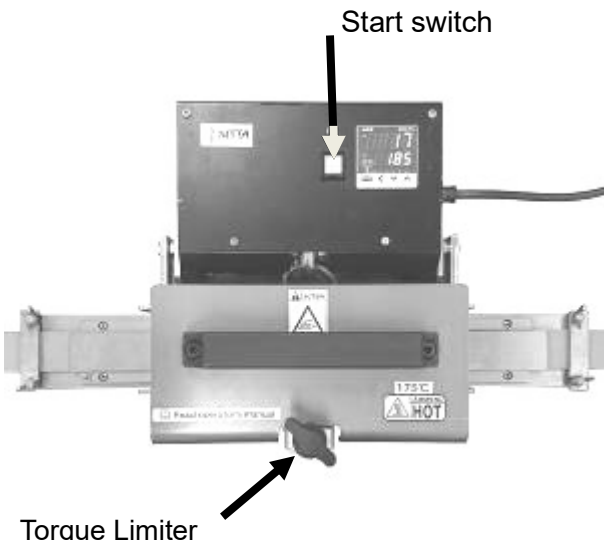
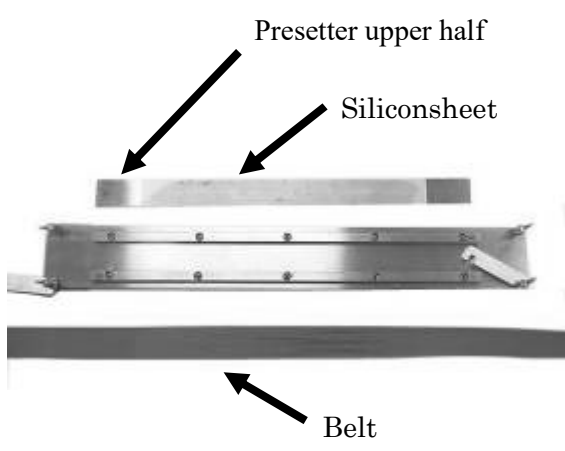
Figure/Photo	Description
 <p>Temperature controller</p> <p>Start switch (Do not touch now.)</p> <p>Fig. h</p>	<p>1) Connect the power plug to the socket.</p> <p>WARNING Be sure to connect an earth line. Failure to do this may cause electric shock.</p> <p>2) Set the preset temperature and hold time on the temperature controller according to sections 7-2) Temperature setting and 7-3) Hold time setting on page 11.</p> <ul style="list-style-type: none"> * Preset temperature and hold time differ by belt widths. Set them by referring to the attached endless condition table. * Avoid touching the start switch before setting the belt and then clamping the hook.

8-4) Endless splicing

Figure/Photo	Description
 <p data-bbox="375 638 566 705">Presetter guide Fig. i</p>  <p data-bbox="518 772 678 806">Start switch</p> <p data-bbox="191 1276 375 1310">Torque Limiter</p> <p data-bbox="438 1310 502 1355">Fig. j</p>  <p data-bbox="438 1444 678 1489">Presetter upper half</p> <p data-bbox="534 1534 694 1568">Siliconsheet</p> <p data-bbox="518 1848 582 1881">Belt</p> <p data-bbox="438 1915 502 1960">Fig.k</p>	<div data-bbox="805 280 1021 347" style="border: 1px solid black; padding: 5px; display: inline-block;">  WARNING </div> <p data-bbox="1029 268 1412 470">This machine reaches a high temperature in operation. Wear heat-resistant gloves when carrying out the following works.</p> <ol style="list-style-type: none"> <li data-bbox="805 504 1412 772">1) Place the pre-setter prepared as described in section 8-2) Belt setting on page 13, between pre-setter guides as shown in Fig. i. <ul style="list-style-type: none"> <li data-bbox="837 638 1356 705">* Place the pre-setter at the center as much as possible. <li data-bbox="837 705 1396 772">* When placing, be careful not to pull out the belt from the pre-setter. <li data-bbox="805 806 1412 1008">2) Gradually close the top cover so that the upper plate is positioned in parallel with the pre-setter. <ul style="list-style-type: none"> <li data-bbox="837 907 1388 1008">* Quick closing the top cover may cause the pre-setter to shift its position or the belt to come off the pre-setter. <li data-bbox="805 1041 1428 1209">3) Set the hook and turn the torque limiter until it slips as shown in Fig. j. <ul style="list-style-type: none"> <li data-bbox="837 1108 1412 1209">* Excessive turning will cause the torque limiter to slip in removing also, disturbing easy removing. <li data-bbox="805 1243 1420 1612">4) Push the start switch to start endless splicing. <ul style="list-style-type: none"> <li data-bbox="837 1310 1420 1478">* It takes about 60 min to finish one cycle of operation (heating, temperature holding and cooling) with the presetting before shipping at 23°C of environmental temperature. <li data-bbox="837 1478 1412 1612">* The required time changes according to ambient environmental temperature or the setting of preset temperature or hold time of the press. <li data-bbox="805 1646 1404 1814">5) On completion of temperature holding, the pilot lamp goes off and operate the cooling fan. Check that the cooling fan has stopped after cooling completion before opening the top cover. <li data-bbox="805 1848 1412 2027">6) Take out the pre-setter and remove the upper one, silicone sheet and belt in order. Fig k <ul style="list-style-type: none"> <li data-bbox="837 1960 1412 2027">* Use the belt after it has cooled down to room temperature.

Figure/Photo	Description
<p data-bbox="164 237 344 271">Torque Limiter</p>  <p data-bbox="440 707 504 741">Fig. 1</p> <p data-bbox="627 674 699 707">Hook</p>	<p data-bbox="807 237 1422 371">7) To continue endless splicing, prepare the pre-setter by following the procedure of section 8-2) Belt setting and then repeat the procedure of section 8-4) Endless splicing.</p> <div data-bbox="807 383 1422 472" style="border: 1px solid black; padding: 2px;">  <p data-bbox="879 405 1422 472">WARNING Be sure to wear heat-resistant gloves when operating the press.</p> </div> <p data-bbox="807 506 1422 640">8) To end operation, check that cooling is completed. Then set the hook and turn the torque limiter to lock before disconnecting the power plug as shown in Fig. 1.</p> <div data-bbox="807 651 1422 775" style="border: 1px solid black; padding: 2px;">  <p data-bbox="879 651 1422 775">WARNING Securely clamp the hook and torque limiter. Insufficient clamping may cause injury.</p> </div>

9. Troubleshooting

Problem	Cause	Solution
No display on the temperature controller	The power plug has been disconnected.	Connect the power plug.
	The fuse has blown out.	Replace the fuse.
	Is power supplied to the outlet?	Yes Failure of the temperature controller or disconnection of power cable or internal wiring is suspected. * Please contact your local distributor, agent in your area or our company.
	No	Supply power to the outlet.
The temperature controller gives a display starting with AL. (AL01 - AL99)	Defective data on temperature controller	Disconnect the power plug once and connect it again. * If the alarm display does not disappear, failure on the temperature controller is suspected. * Please contact your local distributor, agent in your area or our company.
Temperature and hold time cannot be set.	Setting change is not possible for 6 sec. right after power ON.	Wait 6 sec. or more to make a setting.
	The (para) and other buttons were pushed right after the preset value was changed.	To fix the preset value, avoid pushing buttons for 2 sec. or more.
	Other than the above: Failure of the temperature controller	If setting is not possible even by the above methods, failure on the temperature controller is suspected. * Please contact your local distributor, agent in your area or our company.
Cannot be heated to the set temperature.	Does power supply not match the specification?	Yes Use the correct power supply.
		No Failure of the temperature controller or disconnection of internal wiring is suspected. * Please contact your local distributor, agent in your area or our company.
The cooling fan does not operate.	Has preset temperature been set to around 45 °C?	Yes This machine has been set to end cooling at 45 °C. Setting the temperature to around 45 °C may cause the cooling fan to operate incorrectly. Set the preset temperature higher.
		No Failure of the cooling fan or disconnection of internal wiring is suspected. * Please contact your local distributor, agent in your area or our company.
The torque limiter slips and cannot be loosened.	The torque limiter was turned excessively.	Lightly tap the torque limiter from the rear to the front with a plastic hammer while taking care not to give the press any strong jolts. * Throttling force is sufficient when the torque limiter begins to slip.
The splice part shows air bubbles	Out of grease in the pressure parts	Lightly apply the grease to the pressure parts (see "11. Maintenance").
	The malfunction of the torque limiter	If not corrected by applying grease, the torque limiter should be checked. * Please contact your local distributor, agent in your area or our company.

10. Inspection

Check item	Date/check	Date/check	Date/check	Date/check	Date/check
The power cable have no flaw.					
The temperature controller is not damaged.					
There is no screw or part missing.					
The machine body is not damaged.					
Heat plates have no resin or foreign matter adhered.					
The pre-setter have no flaw.					
The pre-setter have no resin or foreign matter adhered.					
The hook or the torque limiter have no distortion.					

* Please make copies of this page and use them for daily check before use.

11. Maintenance

Applying grease to the pressure parts

Lightly apply the grease periodically to the point shown below ① through ④. This will deliver a correct pressure. However please do not apply excessively.

- ① screw
- ② boss of the screw
- ③ boss of torque limiter
- ④ sliding part of metal plate

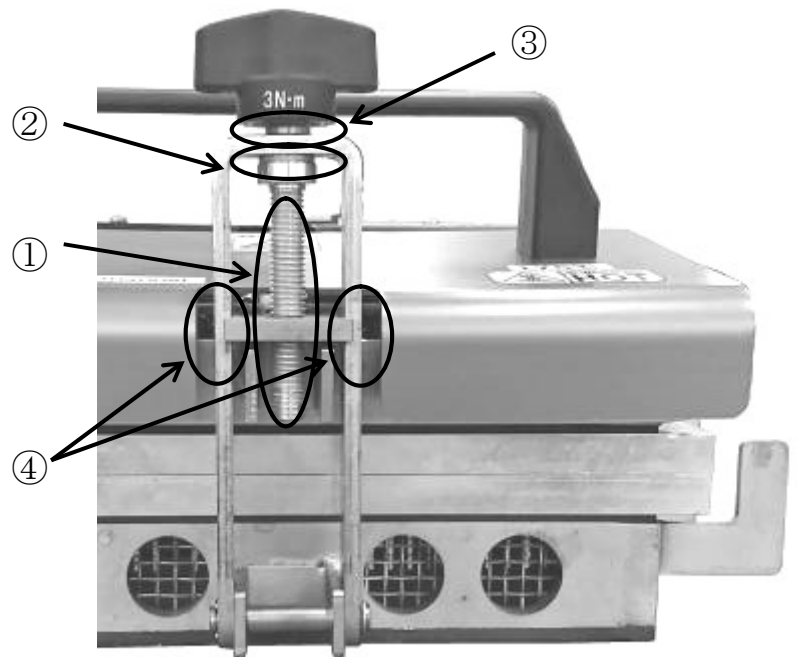

12. Warranty and after-sales service

1. Warranty period

The warranty period is for one full year after the delivery of the order at your appointed place.

2. Warranty coverage

1) Should the product malfunction due to causes for which our company is responsible during the abovementioned warranty period, our company will provide a replacement product or repair the product free of charge. However, even within the warranty period the following cases shall not be covered by the warranty. Please note that even if our company provides a replacement product or repairs the product, the warranty period will be calculated from the initial date on which the product was delivered.

- ① Malfunction arising from any inappropriate conditions, environment, handling and usage which are not described in the Operation Manual and the Endless Splicing Procedure.
- ② Malfunction due to a cause arising from something other than the product, such as your own device.
- ③ Malfunction arising from any remodeling or repairing by other than our own company.
- ④ Malfunction arising from any reasons unpredictable due to our level of chemistry and technology before shipment.
- ⑤ Malfunction arising from fire, earthquake, flood, other disasters, voltage error, or other external factors for which our company bears no responsibility.

2) The warranty coverage is limited to what is stated in 1) above, and the warranty does not cover secondary damages (equipment damage, opportunity loss, profit loss) and any other damage incurred by the user as a result of a malfunction of the product.

3) After the warranty period, if after examination the product is repairable, our company will repair it upon request.

NITTA CORPORATION

4-4-26 Sakuragawa Naniwa-ku, Osaka 556-0022 Japan
Phone:+81-6-6563-1225 Fax:+81-6-6563-1242
<https://www.nitta.co.jp/en>



NITTA CORPORATION OF AMERICA

7605 Nitta Drive, Suwanee, GA 30024, U.S.A.
Phone:+1-770-497-0212 Fax:+1-770-623-1398
<http://www.nitta.com>

NITTA CORPORATION OF HOLLAND B.V.

Berenkoog 25, 1822 B.H. Alkmaar, The Netherlands
Phone:+31-72-5622234 Fax:+31-72-5613238
<http://www.nitta.nl>

NITTA(SHANGHAI)MANAGEMENT CO.,LTD

Room2705, Shenggao International Building, No.137 Xianxia Road, Shanghai 200051 CHINA
Phone:+86-21-6229-6000 Fax:+86-21-6229-9606
<http://www.nitta-cn.com>

NITTA CORPORATION INDIA PVT. LTD.

Gat No 191, 192, and 193, Plot No B, Village Vadhu Khurd, Taluka Haveli Dist Pune-412216, INDIA
Phone:+91-20-6731-3400 Fax:+91-20-6731-3401
<http://www.nitta.co.in>

KOREA NITTA MOORE CORP.

53, Suchul-daero 5-gil, Gumi-si, Gyeongbuk-do, 39266, KOREA
Phone:+82-54-461-5575 Fax:+82-54-461-5350
<http://www.nitta.co.kr/>

TAIWAN NITTA FILTER CO.LTD.

Headquarters: Chia Hsin Building 10FL Room No. 1005, 96 Chung Shan North Road Section 2, Taipei, Taiwan
Phone:+886-2-2581-6296 Fax:+886-3-469-0260
<http://www.nitta.com.tw>

NITTA INDUSTRIES EUROPE GmbH

Heerdter Lohweg 35, 40549 Dusseldorf, Germany
Phone:49-211-537535-0 Fax:+49-211-537535-35
<http://www.nitta.de>

NITTA CORPORATION OF SINGAPORE PTE LTD.

120 Lower Delta Road, #05-07/08 Cendex Centre, Singapore 169208
Phone:+65-6438-8738 Fax:+65-6438-8793
<http://www.nitta.com.sg>
<Liaison Office> Indonesia, Vietnam

NITTA CORPORATION (THAILAND) LIMITED

7/472 Moo 6, Tambol Mabyangporn, Amphur Pluakdaeng, Rayong Province 21140, THAILAND
Phone:+66-38-018-301 Fax:+66-38-018-304
<http://www.nittathai.com>

NITTA BRASIL

Rua Francisco Mommenshon, 50B, Galpão 02 Laranjeiras, Caieiras, São Paulo, Brazil
Phone/Fax:+55-11-4441-2922
<http://www.nitta.com.br>

CONNECT CONVEYOR BELTING INC.

405 Industrial Drive Unit 3-8, Milton, Ontario Canada L9T 5B1
Phone:+1-905-878-5552 FAX:+1-905-878-0344
<http://www.connectbelting.com>

The specification is subject to change for improvement without notice.

Oct, 2020 Rev2 NPS-2005A E