

Finger Puncher FP-200 OPERATOR'S MANUAL

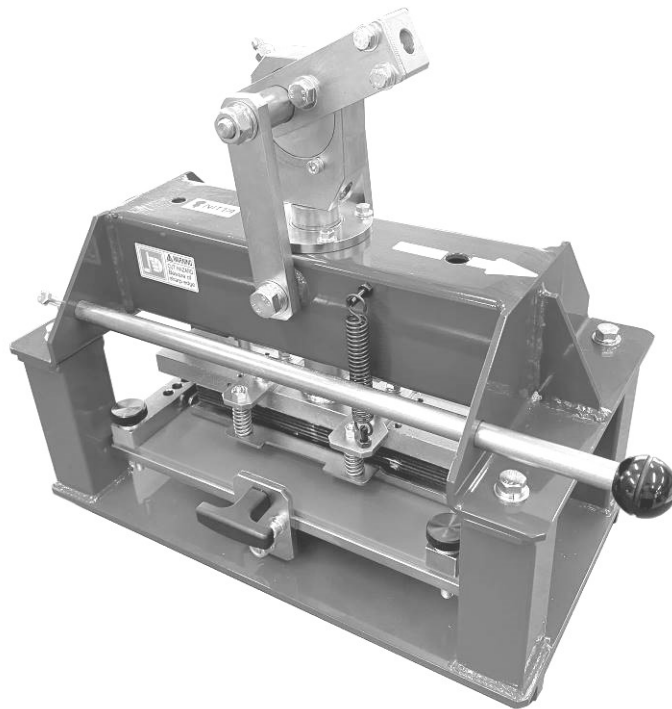

Follow this manual when using the Finger Puncher.



Please pass this manual to the Finger Puncher users for a safe and trouble-free operation.

NITTA CORPORATION

Table of Contents

1. Precautions for the Safety	2
2. Confirmation of Product	4
3. Specification	4
4. Operation Environment	5
5. Storage Environment	5
6. Name of each parts	6
7. How to Make a Finger Joint	7
8. Troubleshooting	9
9. Spare parts	9
10. Maintenance	9
11. Inspection	12
12. Parts List	13
13. Warranty and after-sales service ..	15

1. Precautions for the Safety

Please go over these safety precautions carefully to secure a correct and safe operation of the Finger Puncher FP-200

 **WARNING** Disregarding instructions marked with this symbol may lead to death or serious injury.

 **CAUTION** Disregarding instructions marked with this symbol may lead to injury or property damage.

 **WARNING**

 **WARNING** Do not use the Finger Puncher for any application other than the intended purpose of making belts endless.
Use for any unintended purpose may cause an unexpected accident.

 **WARNING** A person with experience and skills should always operate, maintain and inspect the Finger Puncher.
Handling by an inexperienced person may cause injury.

 **WARNING** Do not dismantle or remodel the Finger Puncher under any circumstance. Please note the Finger Puncher uses a sharp blade.
Dismantling or remodeling the Finger Puncher may cause physical injury.
For repair or inspection, please contact Nitta, your local distributor or agent in your area.

 **WARNING** Use a dry cloth for cleaning the Finger Puncher. To prevent fire, do not use alcohol, benzine, thinner or any other inflammable solvent.



This machine is not intended for the physical, sensory or mental handicapped persons use. They must have the supervision of a person responsible for their safety, if they use this machine.

Failure to do this may cause injury.



Do not allow the child to handle this machine. Keep this machine in the place where child's hand does not reach.

Failure to do this may cause injury.

Caution



Do not use the Finger Puncher under the following conditions:

- Under a corrosive gas environment
- Under an ambient temperature of 5°C or below
- Under an ambient temperature of 40°C or above
- Under a high humidity environment (humidity surpassing 85%)
- In places exposing the puncher to steam or water drops



To prevent physical injury, use the Finger Puncher on a stable working bench or table that will not collapse.



Before using the Finger Puncher, be sure to inspect the puncher in accordance with the procedure described on page 12 to help prevent injury.

2. Confirmation of Product

Thank you for choosing our Finger PuncherFP-200



Check that the product is exactly what you have ordered. Use of the wrong product may cause injury.

2-1) Confirmation of Product

Confirm the following items upon accepting delivery of your order. Contact Nitta, your local distributor or agent in your area if you find any deficiency or defect in your item.

- ① Are descriptions on the face plate the same as those of your order item?
Please confirm the model type.
- ② Has the product been damaged during transportation?
- ③ Has a nut or screw slacked?

2-2) How to Read Face Plate

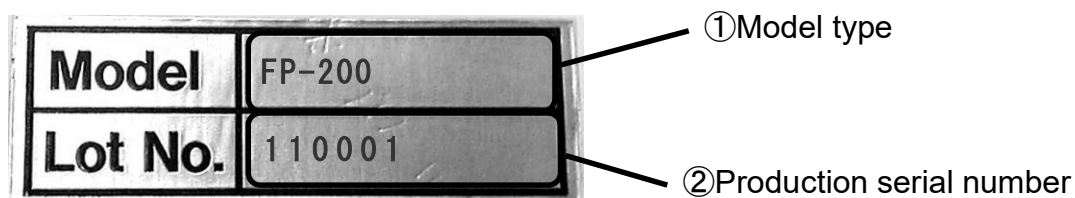

2-3) Inquiries

When making inquiries, please inform our sales representative of the model type and the production serial number.

3. Specifications

3-1) Outline of Finger Puncher

- ①The Finger Puncher is exclusively designed for manually punching finger splice able NITTA's Carryflex CFTG belts with a cutting blade assembly.
- ②The Finger Puncher is compatible with the following endless specifications:

Finger geometry	200mm length×10mm pitch
Belt wide	60mm
Belt thickness	3.9mm or less

3-2) Major Specifications of Finger Puncher

Type	FP-200
Outer Dimension	232 mm W x380 mm Lx385 mm H
Weight	21.0kg

4. Operation Environment

Ambient Temperature	5-40°C (no condensation)
Ambient Humidity	15-85%RH
Place of Use	Indoors (free from dust, water)
Environment	No inflammable, combustible or corrosive gas; no steam



CAUTION

Use the Finger Puncher under the above conditions.

5. Storage Environment

Ambient Temperature	5-40 °C (no condensation)
Ambient Humidity	15-85%RH
Place of Use	Indoors (free from dust, water)
Environment	No inflammable, combustible or corrosive gas; no steam



CAUTION

When the Finger Puncher is not in use, it should be stored under the above conditions.

6. Name of Each Parts

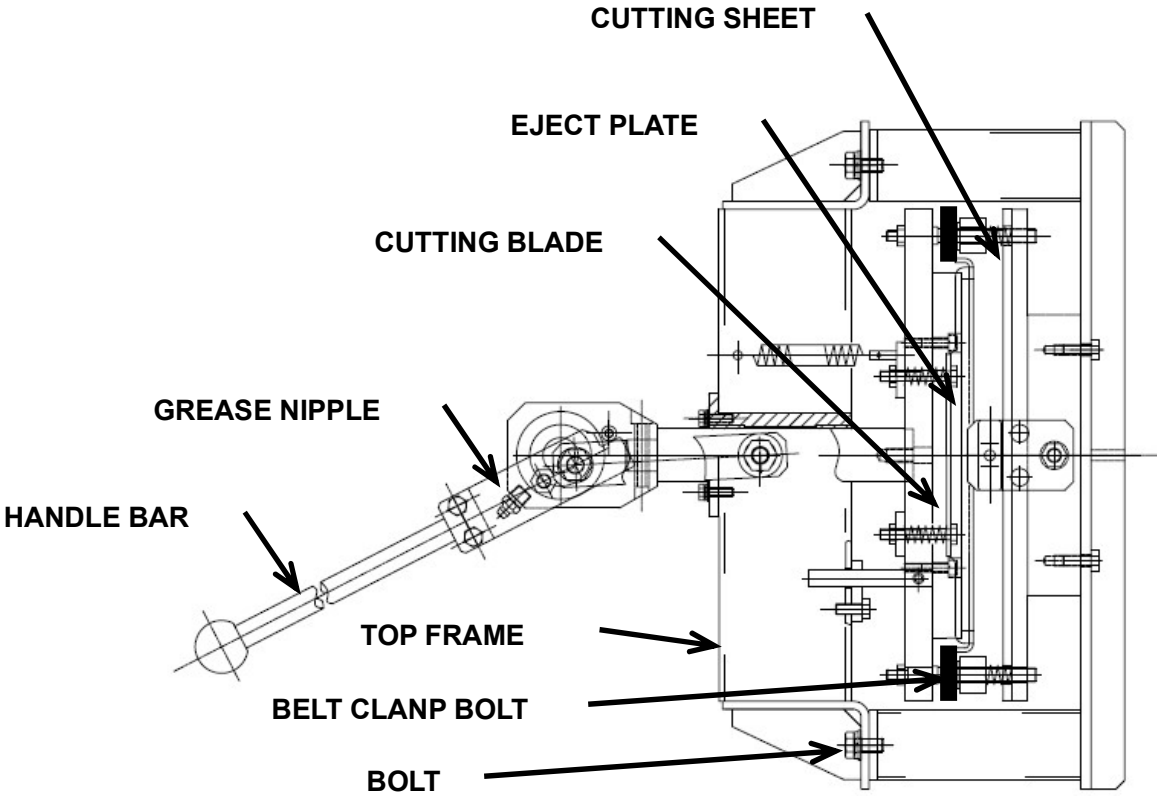
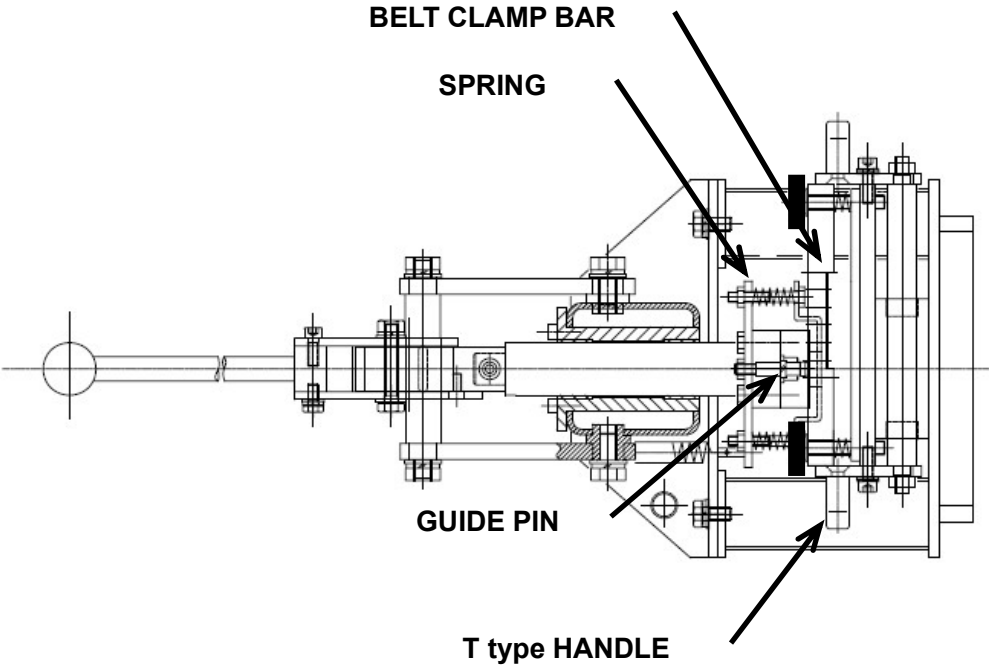

7. How to Make a Finger Joint

7-1) Required Tool (tool prepared in advance)

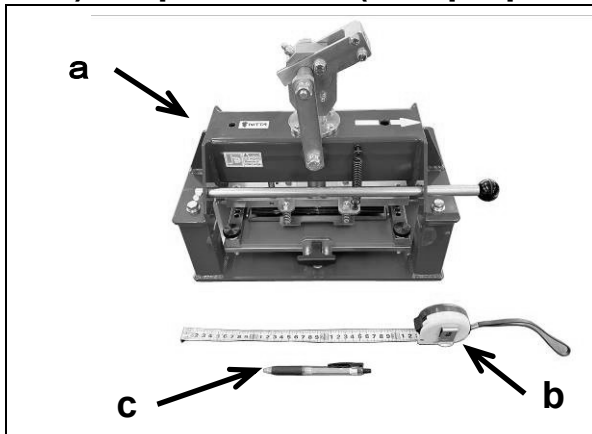

- a. Finger Puncher
- b. Tape Measure or Ruler
(for measurement of belt length)
- c. Ballpoint Pen or Felt Pen (for marking)

7-2) How to Measure Belt Length

Measure belt length and mark on the belt.

1) Measure Length from cut end.

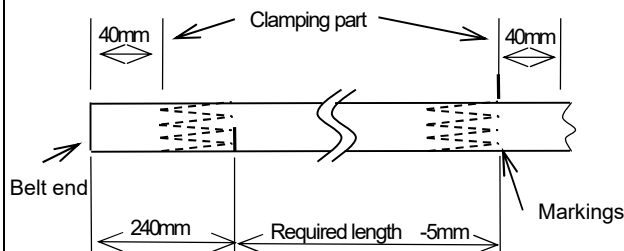

- ① The first mark 240mm from the edge of the belt. (See diagram to left.)
- ② Based on the first mark, make a second mark at the ending point of the required belt length -5mm. (Put both marks on the front side, i.e. on the operator side.)

2) Measure length from finger end
(For continuous measuring)

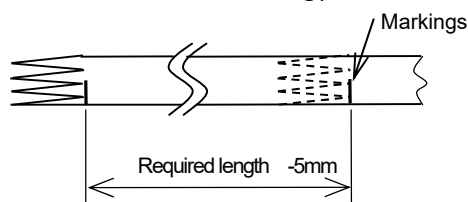

- ③ When consecutively making endless belts, obtain required belt length and from the second mark made at the preceding finger joint, measure out the required belt length and make another mark. Repeat the above process. By doing this, punching can always be made at the right position and there will be no wasted belt.

7-3) How to Make a Finger Joint

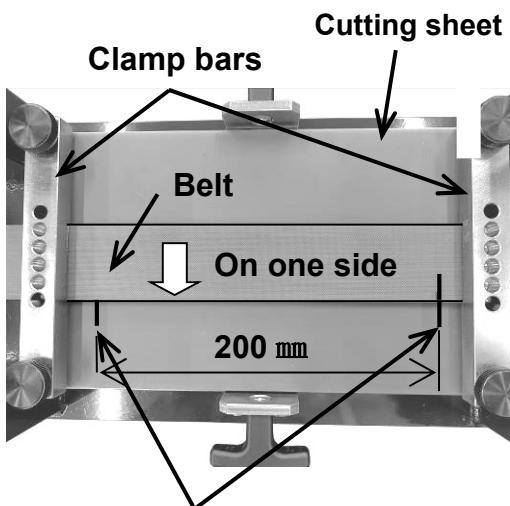
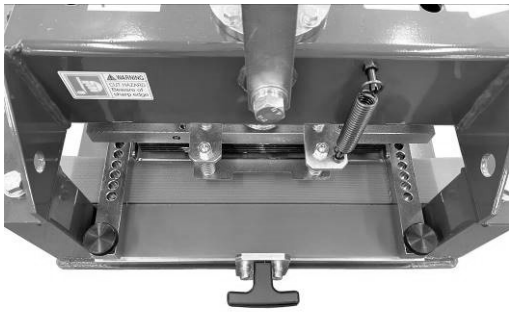

Mark 200 mm joint length on the table.
Set both belt ends to same side of the clamp.

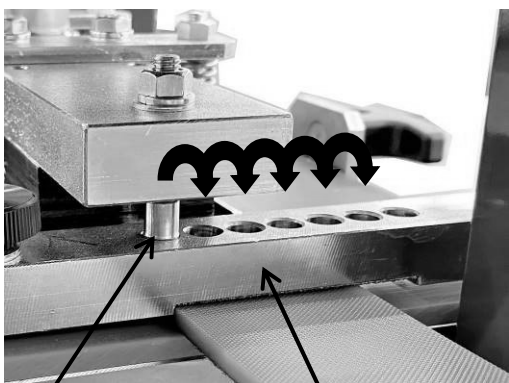

Guiding pins

Clamp bars

- ① Loosen bolt on clamping bar and insert a belt end in one side of finger puncher.
- ② Place the belt to coincide marks on the belt and the table.
- ③ Fasten the bolts on both clamps to secure the belt position.

NO

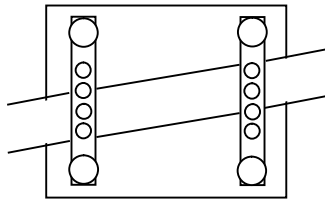

NO

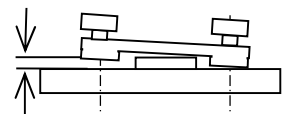

- ④ Continuous punching
After punching one end of a belt, pull out the Belt through clamping bar until next punching position.
- ⑤ Both ends cut belt
Each ends must be insert from opposite side clamping bar and place the same side edge of groove of the clamping bar.
- ⑥ Align the support table so that guide pins on the cutter line up with a set of alignment holes on either end of the clamps.
- ⑦ Push downward on the handle carefully to check the alignment of the pins.
- ⑧ Return the handle and move the support table over so the next set will accept the guide pins.
- ⑨ Repeat step ⑥-⑧.

8. Troubleshooting

If there are any finger joints which are not cut out properly when a belt is punched, follow the directions described in the “Maintenance” section on pages 9-11.

If the problem is not solved after following these directions, please contact Nitta, your local distributor or agent in your area for advice.

9. Spare parts

1. Cutting sheet
 2. Cutting blade
-

10. Maintenance

10-1) How to Perform Maintenance

If the handle bar does not move smoothly, Grease is injected from the grease nipple.

You can change the position of the cutting sheet and both sides of the cutting sheet can be used. Adjusting the position may solve any problems where a portion of the finger joint is not cut out.

The cutting sheet and the cutting blade are consumable. Specify the cutting sheet and the cutting blade for Finger Puncher when you order a new one.

10-2-1) How to Grease cam holder

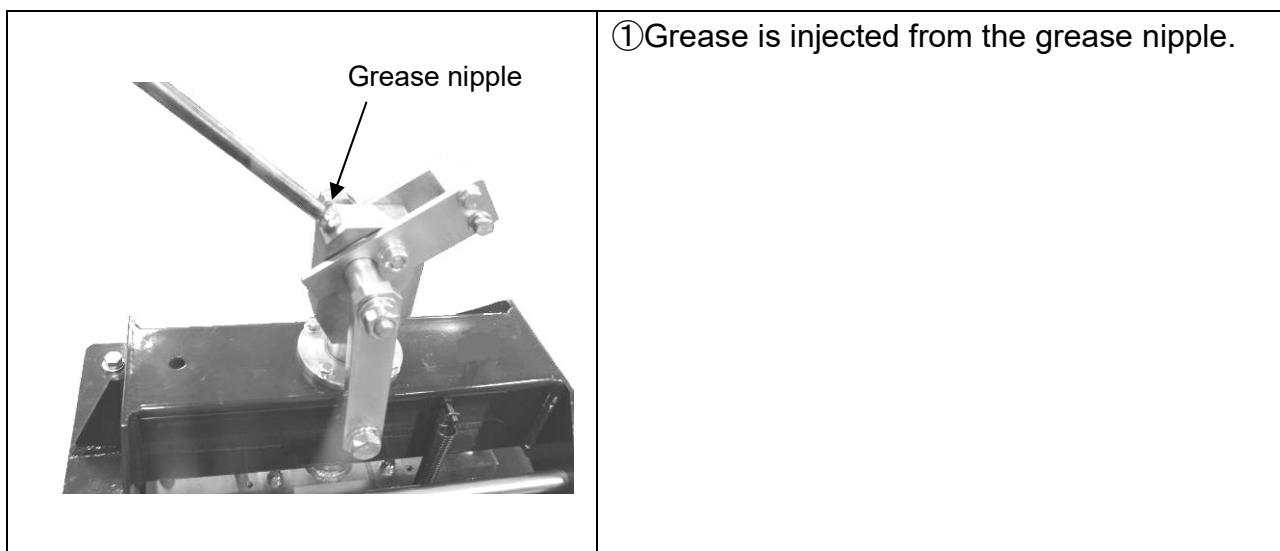

10-2-2) How to the cutting sheet board can use both sides.

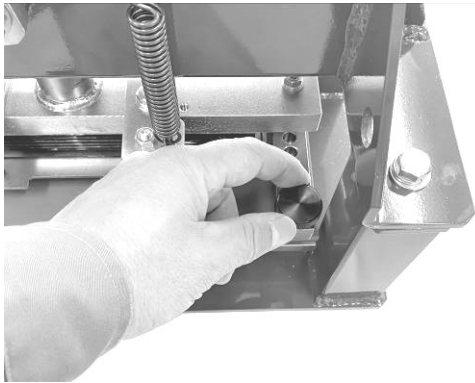

- ① Loosen the bolt, and the bolt, the clamping bar, and springs are detached.
※ Be careful not to lose them taken out of the finger puncher.

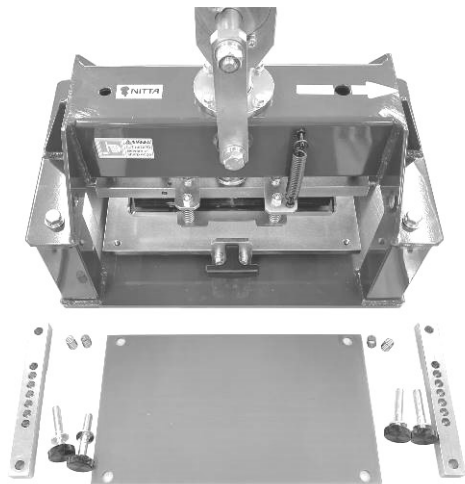

- ② Reverse the cutting sheet to turn the unused side up and insert it back to the finger puncher.

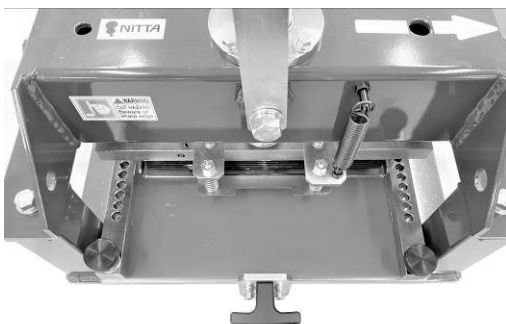

- ③ Installed the springs, the clamp bars and the bolt.

10-2-3) How to Exchange of cutting blade.

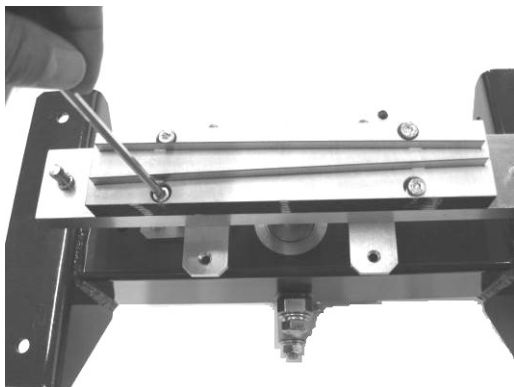
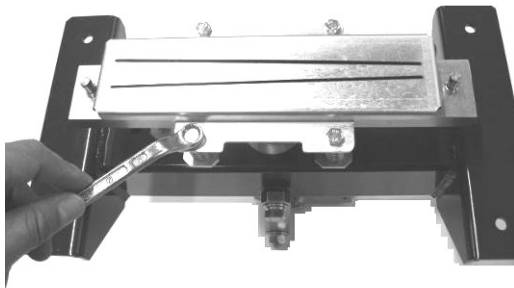
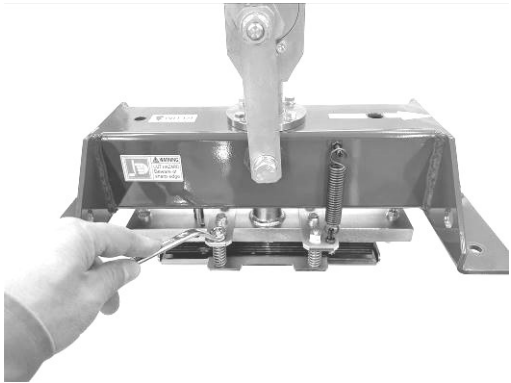
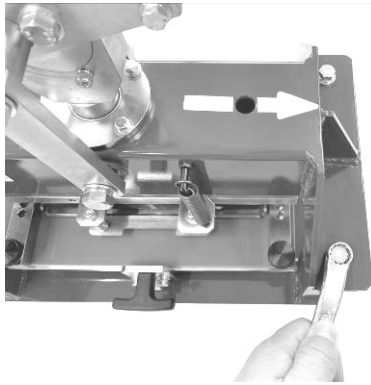

① Loosen the bolt, and the Top Frame is detached.

※ Be careful not to lose them taken out of the finger puncher.

② The nut of the eject plate fixation bolt is loosened.

③ Loosen the bolt, and the eject plate are detached.

④ Loosen the bolt, and the cutting blade are detached.



Please never feel after the eject plate. It is likely to injure it by the cutting blade.

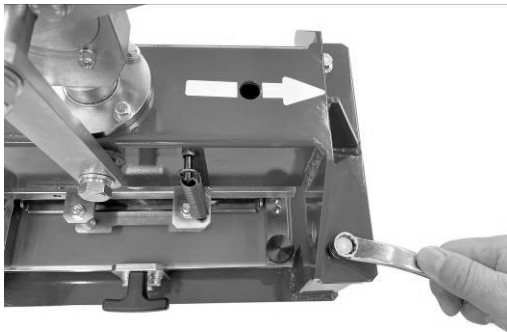
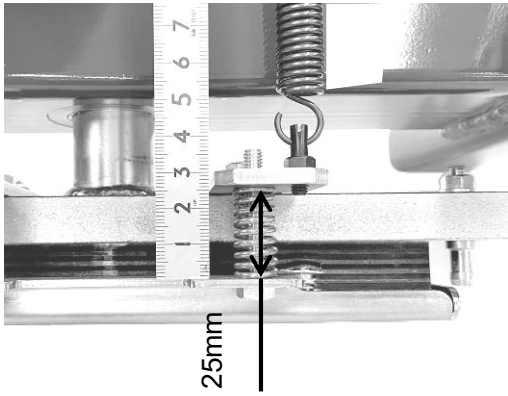

⑤ Tighten the bolt, and the eject plate is assembled.

※ Adjust the clearance between the eject plate and the bracket to 25 mm.

⑥ Tighten the bolt, and the upper frame is assembled.

※ Push downward on the handle carefully to check the alignment of the pins.

11. Inspection

Inspection items	date/staff	date/staff	date/staff	date/staff	date/staff
The puncher body is free of damage or destruction.					
All screws of the puncher body are tightened.					
The belt can be completely punched out.					

Make a copy of this page and use it for inspection prior to each use.

12. Parts List

#	Parts name	Parts number	Pcs	Remarks
1	TOP FRAME	NO2-FP200-P017-D-1	1	
2	BOTTOM FRAME	NO2-FP200-P017-F	1	
3	SPINDLE	NO2-F200-P004-E	1	
4	CAM HOLDER	NO2-F200-P036-D	1	
5	ECCENTRIC CAM	NO2-F200-P035-D	1	
6	ARM BRACKET A	NO2-F200-P037-D	1	
7	ARM BRACKET B	NO2-F200-P038-E	1	
8	HANDLE BAR	NO2-F120-P021-B	1	
9	BALL GRIP	NO2-FP200-A003-D-9	1	BLG30
10	TABLE BRACKET	NO2-FP200-P023-D-1	2	
11	SLIDE TABLE	NO2-FP200-P011-E-RA	1	
12	CUTTING SHEET	NO2-FP200-P012-G	1	
13	DECK PLATE	NO2-FP200-P029-E-RA	1	
14	PRESS HEAD GUIDE	NO2-F120-P007-C	1	
15	PRESS HEAD GUIDE HOLDER	NO2-F200-P008-B	1	
16	BELT CLAMP BAR	NO2-FP200-P019-F-EU	2	
17	SLIDE SHAFT	NO2-FP200-P026-C	1	
18	HEXAGON SOCKET CAP SCREW	NO2-FP200-A003-19	4	M8×45L
19	ECCENTRIC SHAFT	NO2-F200-P020-F-1	1	
20	LINK PLATE	NO2-F200-P002-F	2	
21	HEXAGON HEAD SCREW	NO2-FP200-A003-D-22	2	M10×25L, (PW, SW)
22	SPRING PIN	NO2-FP200-A003-D-23	1	φ8, 36L
23	HEXAGON HEAD SCREW	NO2-FP200-A003-D-24	4	M6×15L, (PW, SW)
24	HEXAGON NUT	NO2-FP200-A003-D-25	2	M8 (PW, SW)
25	HEXAGON NUT	NO2-FP200-A003-D-26	2	M10 (PW, SW)
26	SCREW	NO2-FP200-A003-D-27	2	M6×10L
27	HEXAGON HEAD SCREW	NO2-FP200-A003-D-28	2	M6×12L, (PW, SW)
28	HEXAGON HEAD SCREW	NO2-FP200-A003-D-29	4	M8×15L, (PW, SW)
29	HEXAGON HEAD SCREW	NO2-FP200-A003-D-30	1	M8×45L, (PW, SW, N)
30	HEXAGON SOCKET CAP SCREW	NO2-FP200-A003-D-31	1	M6×15L
31	TENSION SPRING	NO2-FP200-A003-D-32	1	AWS14-70
32	TENSION SPRING POST A	NO2-FP200-A003-D-34	1	BSPO5-25
33	TENSION SPRING POST B	NO2-FP200-A003-D-35	1	ASPO5-20
34	T-TYPE HANDLE	NO2-FP200-A003-D-37	2	TH55N
35	HEXAGON HEAD SCREW	NO2-FP200-A003-D-39	1	M5×10
36	FLOATING SPRING	NO2-FP200-A003-D-40	4	WF10-15
37	HEXAGON HEAD SCREW	NO2-FP200-A003-D-41	4	M6×20L, (PW, SW)
38	SLEEVE	NO2-F120-P006-D	1	
39	HEXAGON HEAD SCREW	NO2-FP200-A003-D-42	4	M5×15L, (PW, SW)
40	PRESS HEAD	NO2-F200-P005-I	1	
41	CUTTING BLADE	NO2-FP200-P030-F	1	
42	EJECT PLATE	NO2-FP00-P041-E	1	
43	EJECT PLATE SET PLATE A	NO2-FP200-P042-C-1	1	
44	EJECT PLATE SET PLATE B	NO2-FP200-P042-C	1	
45	HEXAGON HEAD SCREW	NO2-F200-A001-G-107	4	M6×40L
46	HEXAGON HEAD SCREW	NO2-F200-A001-G-111	4	M6×15L, (PW, SW)
47	HEXAGON NUT	NO2-F200-A001-G-106	4	M6, (SW)
48	HEXAGON SOCKET CAP SCREW	NO2-F200-A001-G-112	4	M5×15L
49	HEXAGON SOCKET SET SCREW	NO2-F200-A001-G-113	1	M4×15L
50	SPRING	NO2-F200-A001-G-108	4	UH13-35
51	GUIDE PIN	NO2-FP200-P022-D	2	
52	OIL FREE BUSHINGS	NO2-F200-A001-G-114	2	MB1610
53	OIL FREE BUSHINGS	NO2-F200-A001-G-115	2	MB3020
54	HEXAGON NUT	NO2-F200-A001-G-117	2	M6 SW
55	GREASE NIPPLE	NO2-F200-A001-G-118	1	R1/8
56	KNOB	NO2-F200-A001-G-119	4	PKN8-B

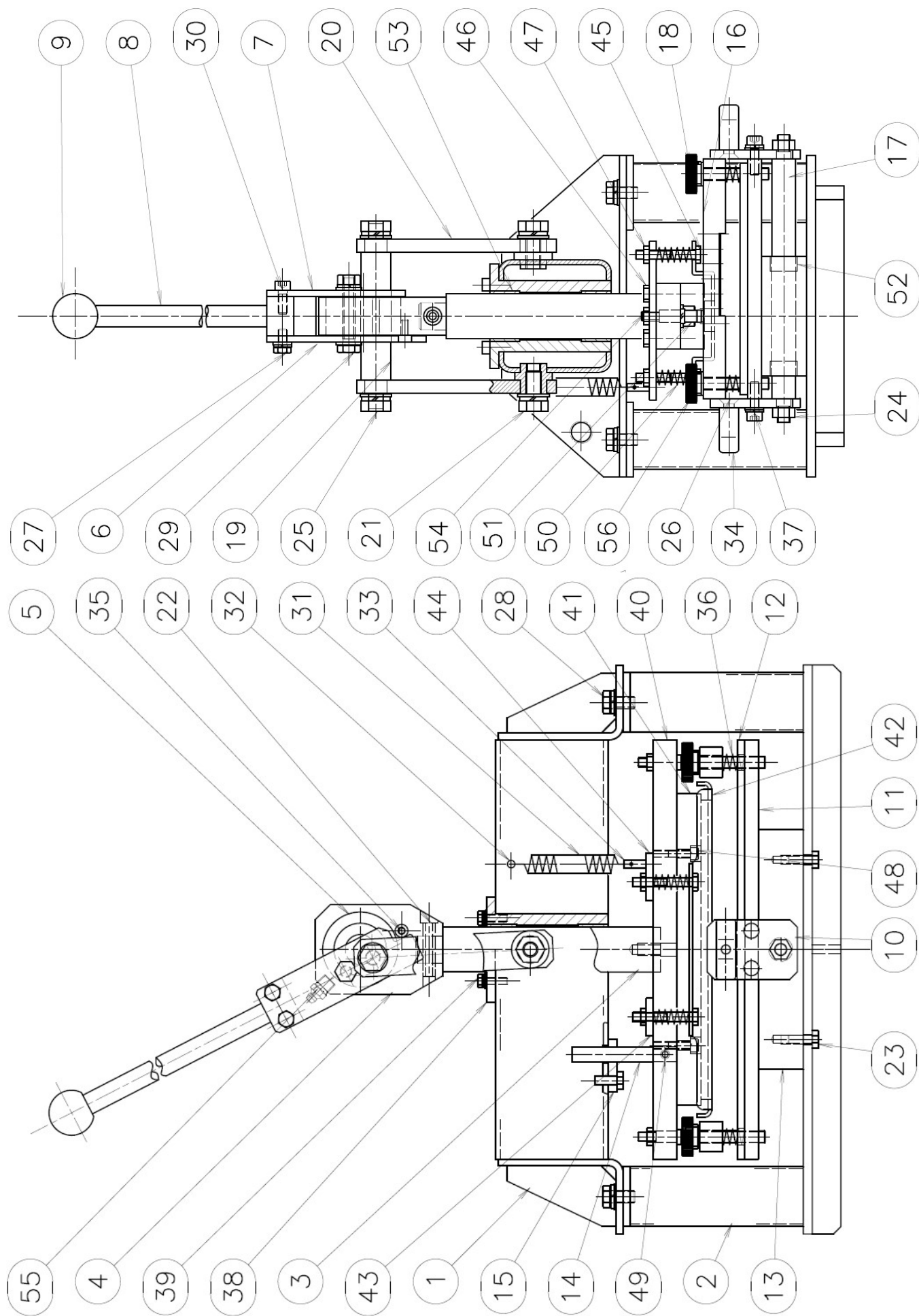

13. Warranty and after-sales service

1. Warranty period

The warranty period is for one full year after the delivery of the order at your appointed place.

2. Warranty coverage

1) Should the product malfunction due to causes for which our company is responsible during the abovementioned warranty period, our company will provide a replacement product or repair the product free of charge. However, even within the warranty period the following cases shall not be covered by the warranty. Please note that even if our company provides a replacement product or repairs the product, the warranty period will be calculated from the initial date on which the product was delivered.

- ① Malfunction arising from any inappropriate conditions, environment, handling and usage which are not described in the Operation Manual and the Endless Splicing Procedure.
- ② Malfunction due to a cause arising from something other than the product, such as your own device.
- ③ Malfunction arising from any remodeling or repairing by other than our own company.
- ④ Malfunction arising from any reasons unpredictable due to our level of chemistry and technology before shipment.
- ⑤ Malfunction arising from fire, earthquake, flood, other disasters, voltage error, or other external factors for which our company bears no responsibility.
- ⑥ Malfunction where it can be confirmed that, if perishables stipulated by the Operation Manual and the Endless Splicing Procedure had been maintained and/or replaced correctly, prevention of the malfunction would have been possible.

2) The warranty does not apply to perishables. When perishables which have a limited lifetime are repaired, and should those perishables be determined by our company to have reached the end of their lifetime, the perishables will be replaced for a fee.

- ① Parts which fall under the category of perishables: "cutting sheet".
- ② Parts which fall under the category of perishables having a limited lifetime: "Cutting blade".

3) The warranty coverage is limited to what is stated in 1) above, and the warranty does not cover secondary damages (equipment damage, opportunity loss, profit loss) and any other damage incurred by the user as a result of a malfunction of the product.

4) After the warranty period, if after examination the product is repairable, our company will repair it upon request.

NITTA CORPORATION

4-4-26 Sakuragawa Naniwa-ku, Osaka 556-0022 Japan
Phone:+81-6-6563-1225 Fax:+81-6-6563-1242
<https://www.nitta.co.jp/en>



NITTA CORPORATION OF AMERICA

7605 Nitta Drive, Suwanee, GA 30024, U.S.A.
Phone:+1-770-497-0212 Fax:+1-770-623-1398
<http://www.nitta.com>

NITTA CORPORATION OF HOLLAND B.V.

Berenkoog 25, 1822 B.H. Alkmaar, The Netherlands
Phone:+31-72-5622234 Fax:+31-72-5613238
<http://www.nitta.nl>

NITTA (SHANGHAI) MANAGEMENT CO., LTD

Room 2705, Shenggao International Building, No.137 Xianxia Road, Shanghai 200051 CHINA
Phone:+86-21-6229-6000 Fax:+86-21-6229-9606
<http://www.nitta-cn.com>

NITTA CORPORATION INDIA PVT. LTD.

Gat No 191, 192, and 193, Plot No B, Village Vadhu Khurd, Taluka Haveli Dist Pune-412216, INDIA
Phone:+91-20-6731-3400 Fax:+91-20-6731-3401
<http://www.nitta.co.in>

KOREA NITTA MOORE CORP.

53, Suchul-daero 5-gil, Gumi-si, Gyeongbuk-do, 39266, KOREA
Phone:+82-54-461-5575 Fax:+82-54-461-5350
<http://www.nitta.co.kr/>

TAIWAN NITTA FILTER CO.LTD.

Headquarters: Chia Hsin Building 10FL Room No. 1005, 96 Chung Shan North Road Section 2, Taipei, Taiwan
Phone:+886-2-2581-6296 Fax:+886-3-469-0260
<http://www.nitta.com.tw>

NITTA INDUSTRIES EUROPE GmbH

Heerdter Lohweg 35, 40549 Dusseldorf, Germany
Phone:49-211-537535-0 Fax:+49-211-537535-35
<http://www.nitta.de>

NITTA CORPORATION OF SINGAPORE PTE LTD.

120 Lower Delta Road, #05-07/08
Cendex Centre, Singapore 169208
Phone:+65-6438-8738 Fax:+65-6438-8793
<http://www.nitta.com.sg>
<Liaison Office> Indonesia, Vietnam

NITTA CORPORATION (THAILAND) LIMITED

7/472 Moo 6, Tambol Mabyangporn, Amphur Pluakdaeng, Rayong Province 21140, THAILAND
Phone:+66-38-018-301 Fax:+66-38-018-304
<http://www.nittathai.com>

NITTA BRASIL

Rua Francisco Mommenshon, 50B, Galpão 02 Laranjeiras, Caieiras, São Paulo, Brazil
Phone/Fax:+55-11-4441-2922
<http://www.nitta.com.br>

CONNECT CONVEYOR BELTING INC.

405 Industrial Drive Unit 3-8, Milton, Ontario Canada L9T 5B1
Phone:+1-905-878-5552 FAX:+1-905-878-0344
<http://www.connectbelting.com>