

Finger Puncher

FP-120G-60

OPERATOR'S MANUAL

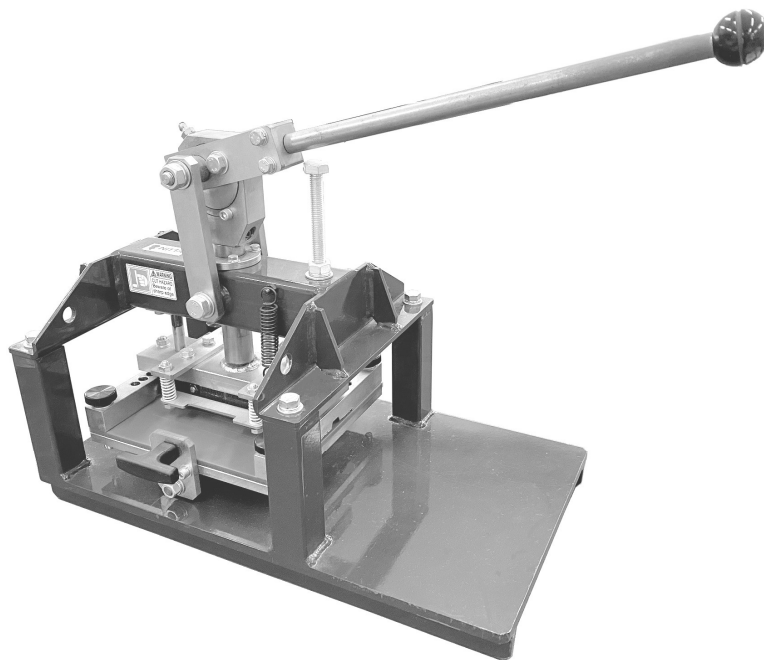

Follow this manual when using the Finger Puncher.



Please pass this manual to the Finger Puncher users for a safe and trouble-free operation.

NITTA CORPORATION

Table of Contents

1. Precautions for the Safety	2
2. Confirmation of Product	4
3. Specifications	4
4. Operating Environment	5
5. Storage Environment	5
6. Name of Each Part	6
7. How to Make a Finger Joint	7
8. Troubleshooting	10
9. Spare Parts	10
10. Maintenance	11
11. Inspection	14
12. Parts List	15
13. Warranty and after-sales service	14

1. Precautions for the Safety

Please go over these safety precautions carefully to ensure correct and safe operation of the Finger Puncher FP-120G-60



WARNING

Disregarding instructions marked with this symbol may lead to death or serious injury.



CAUTION

Disregarding instructions marked with this symbol may lead to injury or property damage.



WARNING



WARNING

Do not use the Finger Puncher for any application other than the intended purpose of making belts endless.

Use for any unintended purpose may cause an unexpected accident.



WARNING

A person with experience and skills should always operate, maintain and inspect the Finger Puncher.

Handling by an inexperienced person may cause injury.



WARNING

Do not dismantle or remodel the Finger Puncher under any circumstance. Please note the Finger Puncher uses a sharp blade. Dismantling or remodeling the Finger Puncher may cause physical injury.

For repair or inspection, please contact Nitta, your local distributor or agent in your area.



WARNING

Do not operate by placing a finger on top of the cutting sheet.

Failure to do this may cause injury.



WARNING

Use a dry cloth for cleaning the Finger Puncher. To prevent fire, do not use alcohol, benzine, thinner or any other inflammable solvent.



WARNING

This machine is not intended for use by the physically, sensory or mentally handicapped. They must have the supervision of a person responsible for their safety, if they use this machine.

Failure to do this may cause injury.



Do not allow children to handle this machine. Keep this machine out of reach of children.

Failure to do this may cause injury.



**This product, weighs 20 kg.
Requires careful attention to lift.
Please lift as in the figure on the right.**

Failure to do this may cause injury.

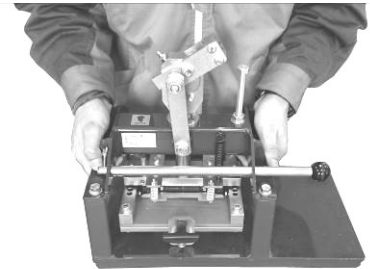

Caution



Do not use the Finger Puncher under the following conditions:

- In a corrosive gas environment
- In ambient temperature of 5C or below
- In ambient temperature of 40C or above
- In a high humidity environment (humidity surpassing 85%)
- In places exposing the puncher to steam or condensation



To prevent physical injury, use the Finger Puncher on a stable working bench or table that will not collapse.



Before using the Finger Puncher, be sure to inspect the puncher in accordance with the procedure described on page 12 to help prevent injury.

2. Confirmation of Product

Thank you for choosing our Finger Puncher FP-120G-60



Check that the product is exactly what you have ordered. Use of the wrong product may cause injury.

2-1) Confirmation of Product

Confirm the following items upon accepting delivery of your order. Contact Nitta, your local distributor or agent in your area if you find any deficiency or defect in your item.

- (1) Are descriptions on the face plate the same as those of item ordered?
Please confirm the model type.
- (2) Has the product been damaged during transportation?
- (3) Has a nut or screw come loose?

2-2) How to Read Face Plate

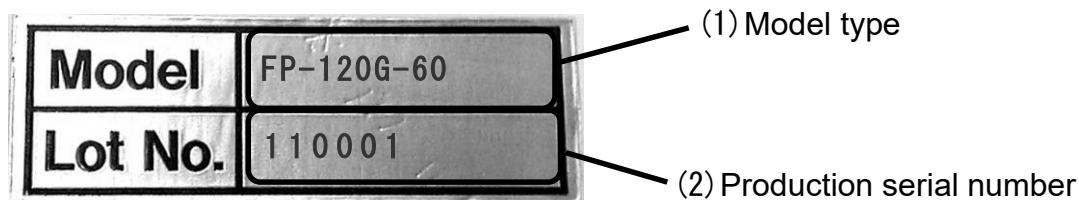

2-3) Inquiries

When making inquiries, please inform our sales representative of the model type and the production serial number.

3. Specifications

3-1) Outline of Finger Puncher

(1)The Finger Puncher is exclusively designed for manually punching finger splice-able NITTA Carryflex CFTG-18G/CFTG-18SG belts with a cutting blade assembly.

(2)The Finger Puncher is compatible with the following endless specifications:

Finger geometry	120mm length×10mm pitch
Belt width	MAX. 60mm
Belt thickness	7.5mm or less

3-2) Major Specifications of Finger Puncher

Type	FP-120G-60
Outer Dimension	260mm W x 420mm L x 372mm H
Weight	20.0kg

4. Operating Environment

Ambient Temperature	5-40C (no condensation)
Ambient Humidity	15-85%RH
Place of Use	Indoors (free from dust, water)
Environment	No inflammable, combustible or corrosive gas; no steam



CAUTION

Use the Finger Puncher under the above conditions.

5. Storage Environment

Ambient Temperature	5-40C (no condensation)
Ambient Humidity	15-85%RH
Place of Use	Indoors (free from dust, water)
Environment	No inflammable, combustible or corrosive gas; no steam



CAUTION

When the Finger Puncher is not in use, it should be stored under the above conditions.

6. Name of Each Part

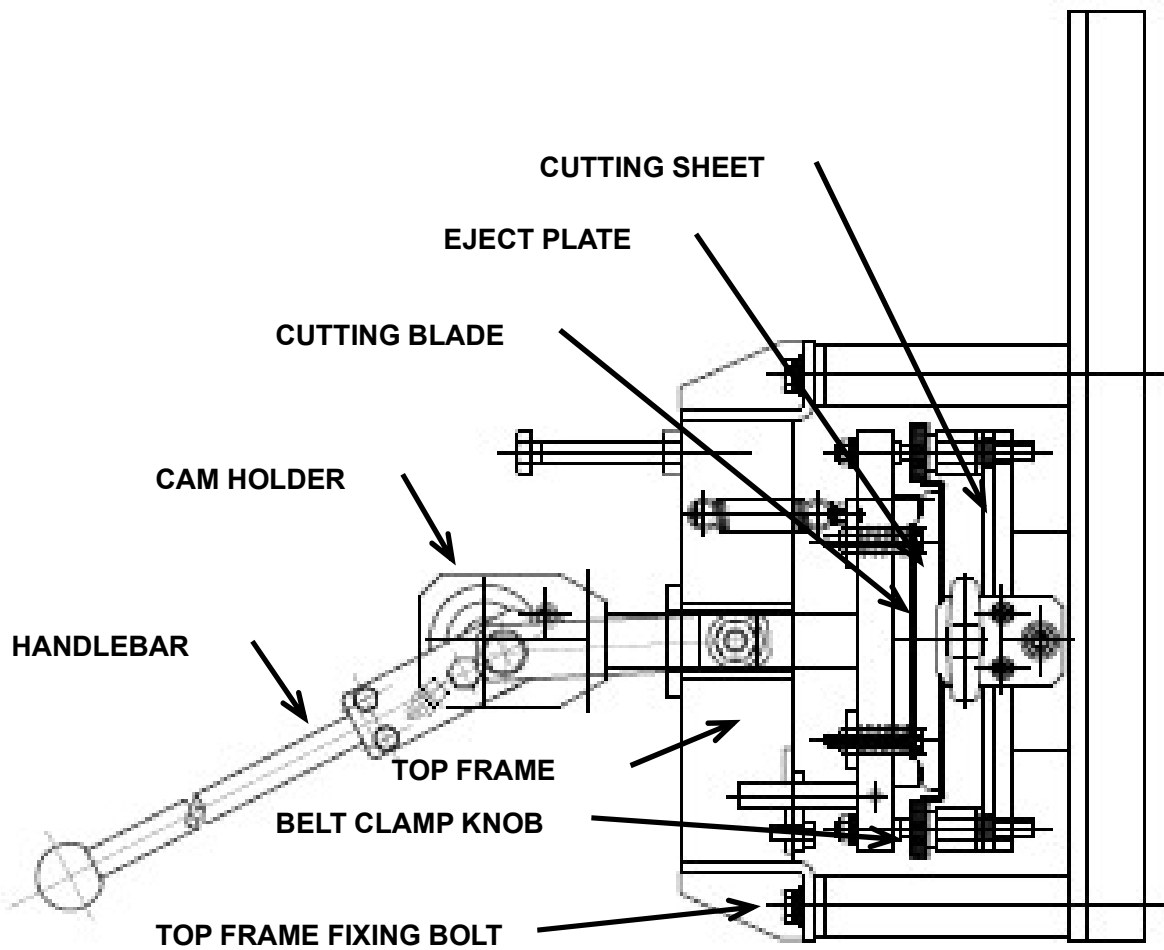
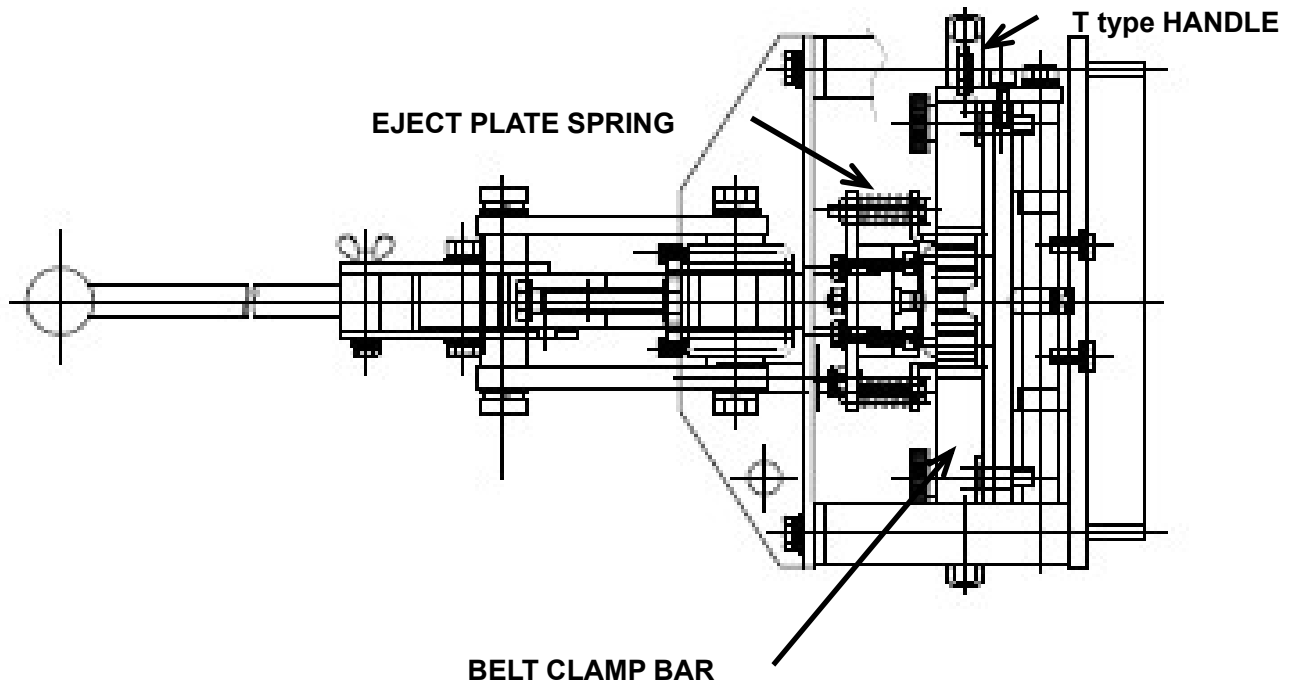

7. How to Make a Finger Joint

7-1) Required Tools (tools prepared in advance)

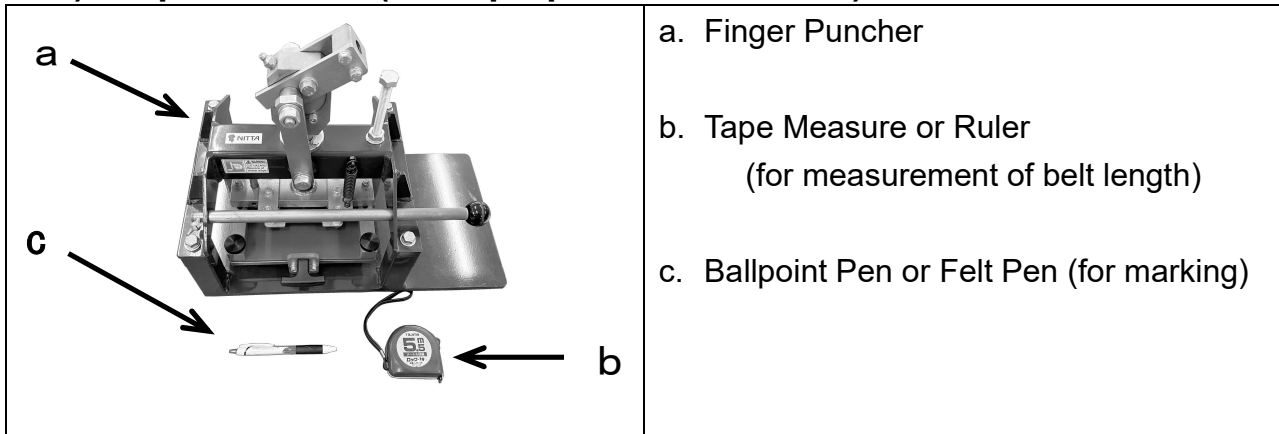

7-2) How to Measure Belt Length

Measure belt length and mark on the belt.

1) Measure Length from cut end.

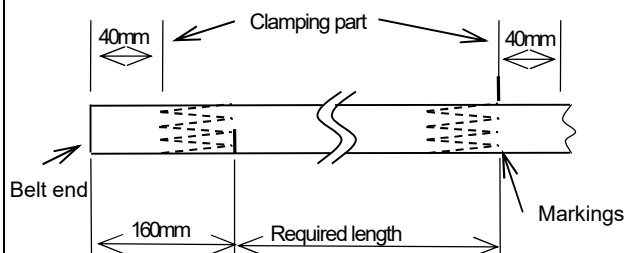

- (1) Make the first mark 160mm from the edge of the belt. (See diagram to left.)
- (2) Based on the first mark, make a second mark at the ending point. (Put both marks on the front side, i.e. on the operator side.)

2) Measure length from finger end
(For continuous measuring)

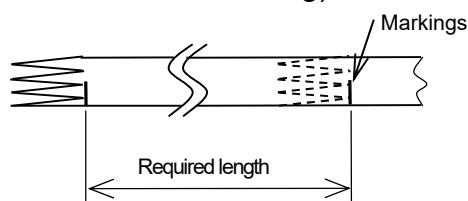

- (3) When consecutively making endless belts, obtain required belt length and, from the second mark made at the preceding finger joint, measure out the required belt length and make another mark. Repeat the above process. By doing this, punching can always be done at the right position and there will be no wasted belt.

7-3) How to Make a Finger Joint

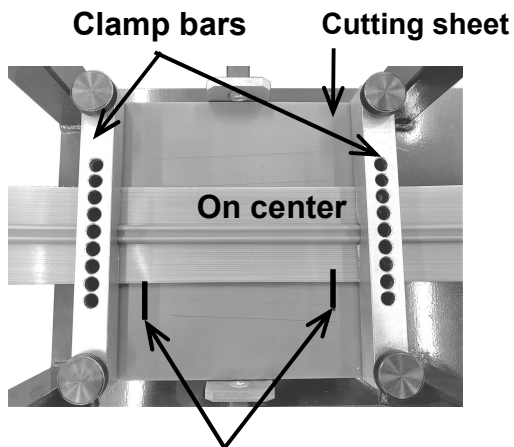
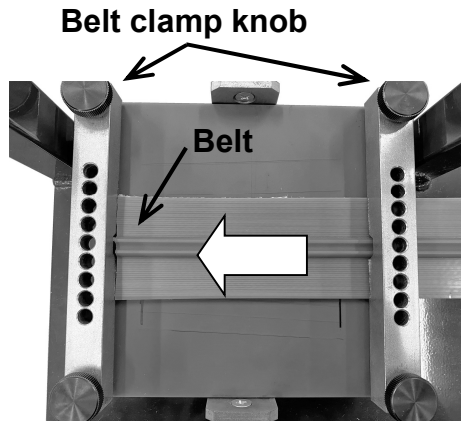

Mark 120 mm joint length on the table.

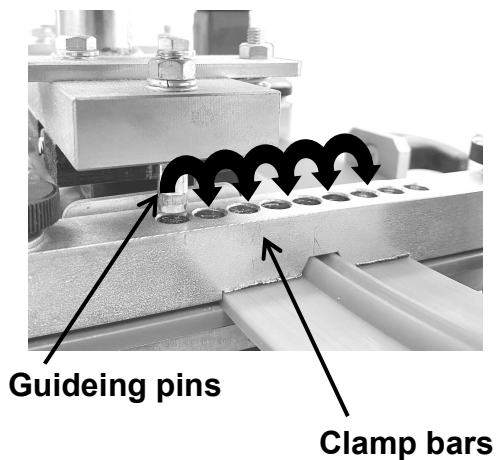

(1) Loosen knob on clamping bar and insert belt end in one side of finger puncher.

(2) Place belt to align marks on belt with inside or outside edge of clamps. Be sure to use this same set position for all punches. Set the belt in center of the clamp bar.

(3) Fasten the knob on both clamps to secure the belt position.

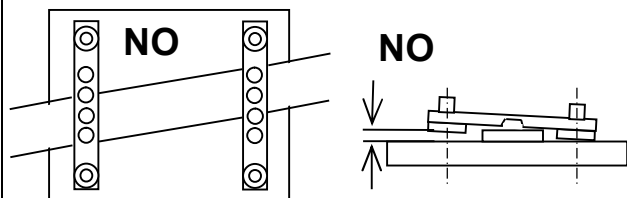

(4) Align the support table so that guide pins on the cutter line up with a set of alignment holes on either end of the clamps.

(5) Push downward on the handle carefully to check the alignment of the pins.

(6) Return the handle and move the support table over so the next set will accept the guide pins.

(7) Repeat steps (5)~(6).

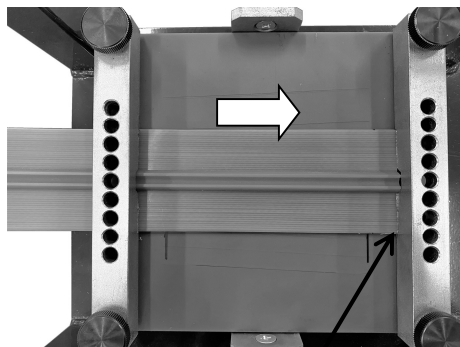
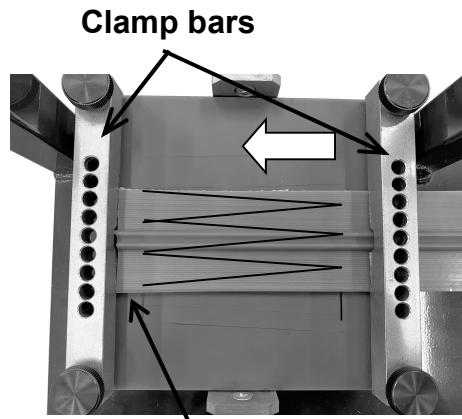

End of belt

(8) Belt insert direction

a) Continuous punching

After punching one end of belt, pull belt through clamping bar until reaching next punching position.

It is effective when the length of the belt is short.

b) Cutting both ends of belt

After punching, feed other end of belt into cutter from opposite direction.

It is effective when the length of the belt is long.

Material loss occurs each time.

8. Troubleshooting

If there are any finger joints which are not cut out properly when a belt is punched, follow the directions described in the “Maintenance” section on pages 9-12.

If the problem is not solved after following these directions, please contact Nitta, your local distributor or agent in your area for advice.

9. Spare Parts

1. Cutting sheet
2. Cutting blade

10. Maintenance

10-1) How to Perform Maintenance

If the handlebar does not move smoothly, inject grease into grease nipple.

You can change the position of the cutting sheet, and both sides of the cutting sheet can be used. Adjusting the position may solve any problems where a portion of the finger joint is not cut out.

The cutting sheet and the cutting blade are consumable. Specify the cutting sheet and the cutting blade for Finger Puncher when you order a new one.

10-2-1) How to Grease Cam Holder

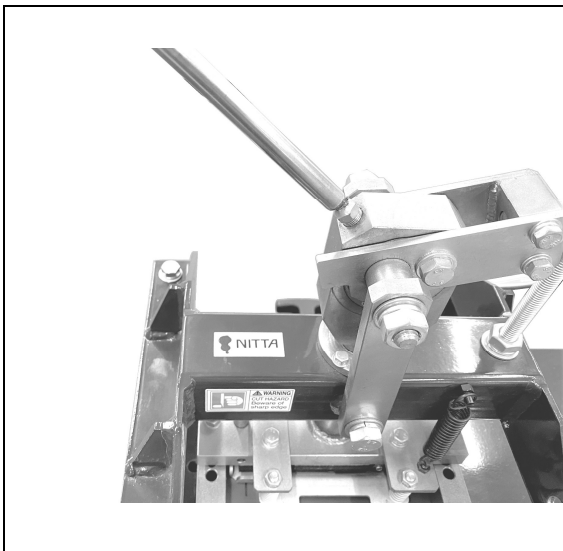

(1) Inject grease into grease nipple.

10-2-2) How to Use Both Sides of Cutting Sheet Board.

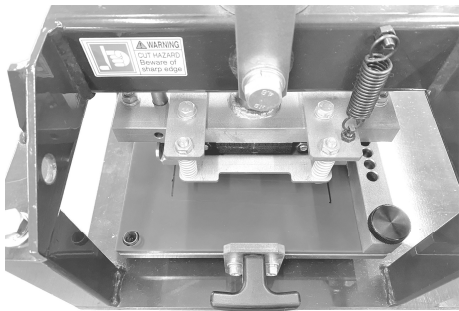
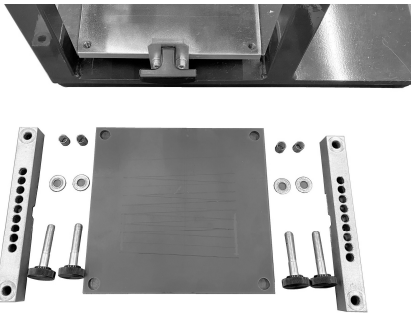
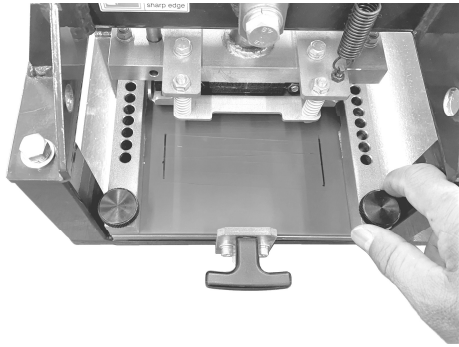

- (1) Loosen bolts to detach bolts, clamping bars and springs.
※ Be careful not to lose them after removing from finger puncher.
- (2) Reverse the cutting sheet to turn the unused side up and insert it back into the finger puncher.
- (3) Install the springs, the clamp bars and the bolts.

10-2-3) How to Change Cutting Blade.

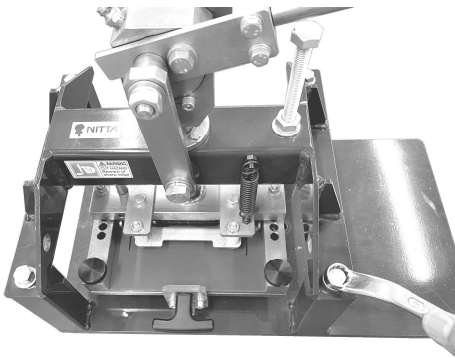

(1) Loosen bolts, and the Top Frame is detached.

※ Be careful not to lose them after removing them from finger puncher.

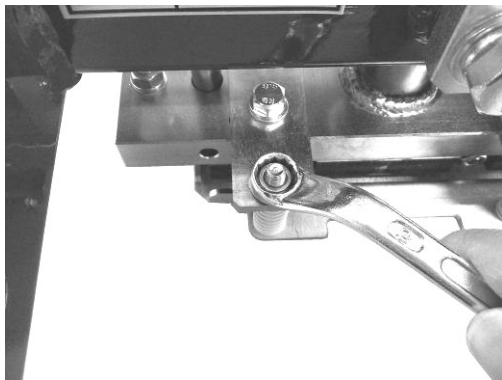

(2) Next, loosen nuts on bolts holding eject plate in place.

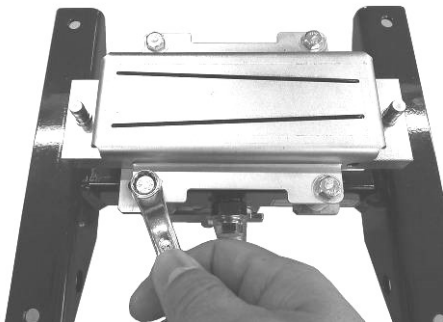

(3) Loosen the bolts, and the eject plate is detached.

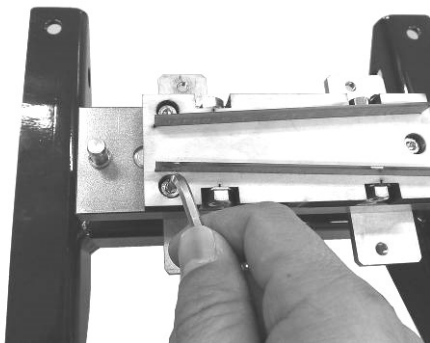

(4) Loosen the bolts, and the cutting blade is detached.



WARNING

Please never touch after removing eject plate.

It is likely to be injured by the cutting blade.

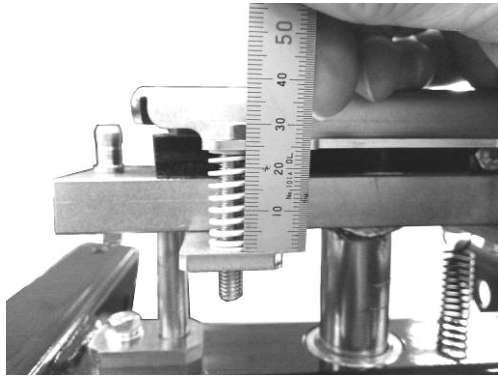

(5) Tighten the bolts, and the eject plate is assembled.

※ The cutting blade is prevented from protruding beyond the eject plate.

※ Set for the spring length to be 24 mm.

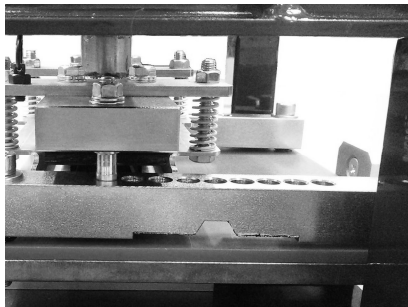

(6) Tighten the bolts, and the upper frame is assembled.

※ Push downward on the handle carefully to check the alignment of the pins at both ends.

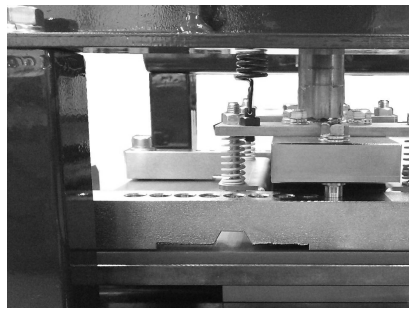

11. Inspection

Inspection items	date/staff	date/staff	date/staff	date/staff	date/staff
The puncher body is free of damage or destruction.					
All screws on the puncher body are tightened.					
The belt can be completely punched out.					

Make a copy of this page and use it for inspection prior to each use.

12. Parts List

#	PARTS NAME	PARTS NUMBER	REMARKE	PIECE
1	BOTTOM FRAME	FP-120G-P001	Z3-01507B	1
2	TOP FRAME	FP-120G-P002	E3-01460D	1
3	BASE BLOCK	FP-120G-P003	E4-01462B	1
4	SLIDE TABLE	FP-120G-P004	E3-01463A	1
5	SLIDE SHAFT	FP-120G-P005	E4-01464A	1
6	TABLE BRACKET	FP-120G-P006	E4-01465	2
7	CUTTING SHEET	FP-120G-P007	E3-01466B	1
8	BELT CLAMP BAR	FP-120G-P008	E3-01467C	2
9	EJECT PLATE	FP-120G-P009	E3-01468B	1
10	PRESS HEAD	FP-120G-P010	E3-01469C	1
11	GUIDE PIN	FP-120G-P011	E4-01470B	2
12	CUTTING BLADE	FP-120G-P012	E4-01471D	1
13	EJECT PLATE SET PLATE A	FP-120G-P013	E4-01472A	1
14	EJECT PLATE SET PLATE B	FP-120G-P014	E4-01473A	1
15	PRESS HEAD GUIDE	FP-120G-P015	E4-01474	1
16	PRESS HEAD GUIDE HOLDER	FP-120G-P016	E4-01475	1
17	SLEEVE	FP-120G-P017	E4-01476	1
18	LINK PLATE	FP-120G-P018	E4-01477	2
19	SPINDLE	FP-120G-P019	E4-01478	1
20	ECCENTRIC CAM	FP-120G-P020	E4-01479	1
21	CAM HOLDER	FP-120G-P021	E4-01480	1
22	ARM BRACKET A	FP-120G-P022	E4-01481	1
23	ARM BRACKET B	FP-120G-P023	E4-01482	1
24	HANDLE BAR	FP-120G-P024	E4-01483A	1
25	BALL GRIP	FP-120G-C025	BLG30	1
26	SPRING PIN	FP-120G-C026	SSPR8-36	1
27	TENSION SPRING	FP-120G-C027	HP140-55-1.6	1
28	TENSION SPRING POST A	FP-120G-C028	BSPO5-15	1
29	TENSION SPRING POST B	FP-120G-C029	AIPOZ5-15	1
30	BALL PLUNGER	FP-120G-C030	BPJ12	1
31	T-TYPE HANDLE	FP-120G-C031	TH55N	2
32	FLOATING SPRING	FP-120G-C032	WL10-10	4
33	EJECT PLATE SPRING	FP-120G-C033	SWR12.5-30	4
34	OIL FREE BUSHINGS FOR DECK PLATE	FP-120G-C034	MDZB16-10	2
35	OIL FREE BUSHINGS FOR SLEEVE	FP-120G-C035	MDZB25-15	2
36	KEY	FP-120G-C036	KES5-25	1
37	GREASE NIPPLE	FP-120G-C037	GPA1	1
38	HANDLE BAR STOPPER BOLT	FP-120G-A038	HEXAGON HEAD BOLT M10×110 N	1
39	BELT CLAMP BAR TIGHTENING SCREW	FP-120G-A039	HEXAGON SOCKET HEAD SCREW M8×45 PW	4
40	LINK PLATE FIXED BOLT	FP-120G-A040	HEXAGON HEAD BOLT M10×25 PW, SW	2
41	DECK PLATE FIXED BOLT	FP-120G-A041	HEXAGON HEAD BOLT M6×16 PW, SW	4
42	SLIDE SHAFT FIXED NUT	FP-120G-A042	HEXAGON NUT M8 PW, PW	2
43	LINK PLATE FIXED NUT	FP-120G-A043	HEXAGON NUT M10 PW, PW	2
44	T-TYPE HANDLE FIXED SCREW	FP-120G-A044	CROSS RECESSED HEAD SCREWS M6×10	2
45	ARM BRACKET JOINT BOLT	FP-120G-A045	HEXAGON HEAD BOLT M6×16 PW, SW	2
46	TOP FRAME FIXED BOLT	FP-120G-A046	HEXAGON HEAD BOLT M8×20 PW, SW	4
47	ARM BRACKET FIXED BOLT	FP-120G-A047	HEXAGON HEAD BOLT M8×45 PW, SW, N	1
48	HANDLE BAR FIXED BOLT	FP-120G-A048	WINGED SCREW M5×20	1
49	ARM BRACKET STOPPER BOLT	FP-120G-A049	HEXAGON SOCKET HEAD SCREW M5×10	1
50	TABLE BRACKET FIXED SCREW	FP-120G-A050	HEXAGON SOCKET HEAD SCREW M6×20 PW, SW	4
51	SLEEVE FIXED BOLT	FP-120G-A051	HEXAGON HEAD BOLT M4×10 PW, SW	4
52	EJECT PLATE FIXED BOLT	FP-120G-A052	HEXAGON HEAD BOLT M6×40 N	4
53	EJECT PLATE SET PLATE FIXED BOLT	FP-120G-A053	HEXAGON HEAD BOLT M6×16 PW, SW	4
54	GUIDE PIN FIXED NUT	FP-120G-A054	HEXAGON NUT M6 SW	2
55	CUTTING BLADE FIXED SCREW	FP-120G-A055	HEXAGON SOCKET HEAD SCREW M5×15	4
56	PRESS HEAD GUIDE FIXED SCREW	FP-120G-A056	HEXAGON SOCKET SET SCREW M4×15	1
57	PRESS HEAD GUIDE HOLDER FIXED BOLT	FP-120G-A057	HEXAGON HEAD BOLT M6×16 PW, SW	1
58	PLUNGER FIXED BOLT	FP-120G-A058	HEXAGON SOCKET HEAD SCREW M12×10	1
59	KNOB	FP-120G-C059	PACK-PKN8-B	4

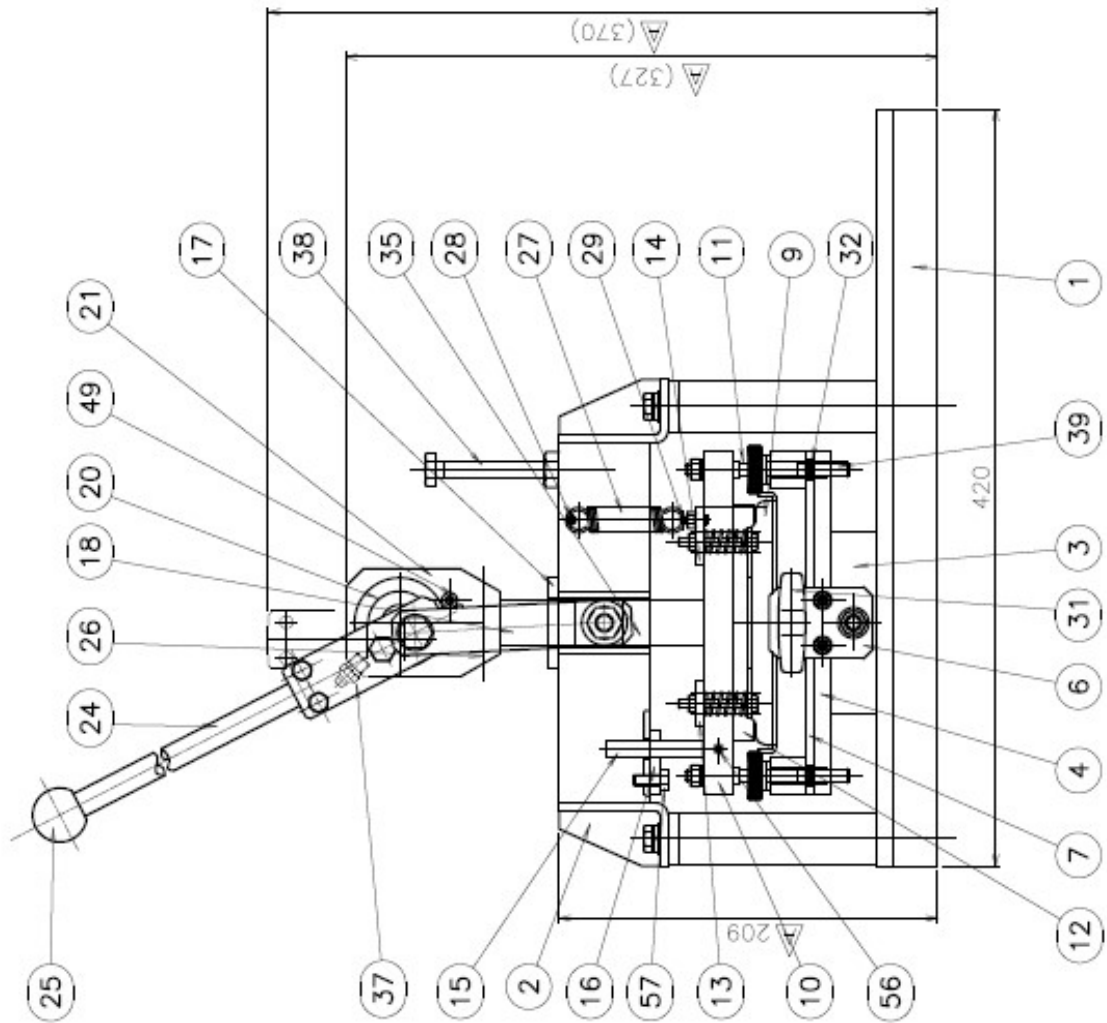
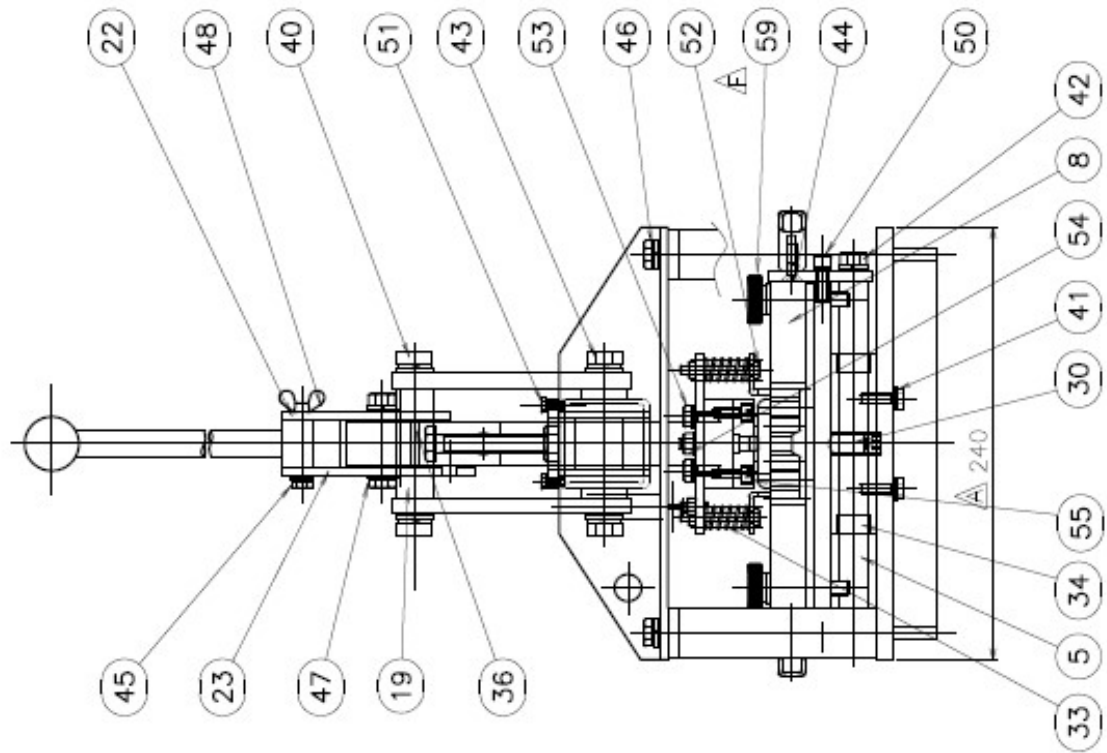

13. Warranty and after-sales service

1. Warranty period

The warranty period is for one full year after the delivery of the order at your appointed place.

2. Warranty coverage

1) Should the product malfunction due to causes for which our company is responsible during the abovementioned warranty period, our company will provide a replacement product or repair the product free of charge. However, even within the warranty period the following cases shall not be covered by the warranty. Please note that even if our company provides a replacement product or repairs the product, the warranty period will be calculated from the initial date on which the product was delivered.

- ① Malfunction arising from any inappropriate conditions, environment, handling and usage which are not described in the Operation Manual and the Endless Splicing Procedure.
- ② Malfunction due to a cause arising from something other than the product, such as your own device.
- ③ Malfunction arising from any remodeling or repairing by other than our own company.
- ④ Malfunction arising from any reasons unpredictable due to our level of chemistry and technology before shipment.
- ⑤ Malfunction arising from fire, earthquake, flood, other disasters, voltage error, or other external factors for which our company bears no responsibility.
- ⑥ Malfunction where it can be confirmed that, if perishables stipulated by the Operation Manual and the Endless Splicing Procedure had been maintained and/or replaced correctly, prevention of the malfunction would have been possible.

2) The warranty does not apply to perishables. When perishables which have a limited lifetime are repaired, and should those perishables be determined by our company to have reached the end of their lifetime, the perishables will be replaced for a fee.

- ① Parts which fall under the category of perishables: "cutting sheet".
- ② Parts which fall under the category of perishables having a limited lifetime: "Thomson blade".

3) The warranty coverage is limited to what is stated in 1) above, and the warranty does not cover secondary damages (equipment damage, opportunity loss, profit loss) and any other damage incurred by the user as a result of a malfunction of the product.

4) After the warranty period, if after examination the product is repairable, our company will repair it upon request.

NITTA CORPORATION

4-4-26 Sakuragawa Naniwa-ku, Osaka 556-0022 Japan
Phone:+81-6-6563-1225 Fax:+81-6-6563-1242
<https://www.nitta.co.jp/en>



NITTA CORPORATION OF AMERICA

7605 Nitta Drive, Suwanee, GA 30024, U.S.A.
Phone:+1-770-497-0212 Fax:+1-770-623-1398
<http://www.nitta.com>

NITTA CORPORATION OF HOLLAND B.V.

Berenkoog 25, 1822 B.H. Alkmaar, The Netherlands
Phone:+31-72-5622234 Fax:+31-72-5613238
<http://www.nitta.nl>

NITTA (SHANGHAI) MANAGEMENT CO., LTD

Room2705, Shenggao International Building, No.137 Xianxia Road, Shanghai 200051 CHINA
Phone:+86-21-6229-6000 Fax:+86-21-6229-9606
<http://www.nitta-cn.com>

NITTA CORPORATION INDIA PVT. LTD.

Gat No 191, 192, and 193, Plot No B, Village Vadhu Khurd, Taluka Haveli Dist Pune-412216, INDIA
Phone:+91-20-6731-3400 Fax:+91-20-6731-3401
<http://www.nitta.co.in>

KOREA NITTA MOORE CORP.

53, Suchul-daero 5-gil, Gumi-si, Gyeongbuk-do, 39266, KOREA
Phone:+82-54-461-5575 Fax:+82-54-461-5350
<http://www.nitta.co.kr/>

TAIWAN NITTA FILTER CO.LTD.

Headquarters: Chia Hsin Building 10FL Room No. 1005, 96 Chung Shan North Road Section 2, Taipei, Taiwan
Phone:+886-2-2581-6296 Fax:+886-3-469-0260
<http://www.nitta.com.tw>

NITTA INDUSTRIES EUROPE GmbH

Heerdter Lohweg 35, 40549 Dusseldorf, Germany
Phone:49-211-537535-0 Fax:+49-211-537535-35
<http://www.nitta.de>

NITTA CORPORATION OF SINGAPORE PTE LTD.

120 Lower Delta Road, #05-07/08
Cendex Centre, Singapore 169208
Phone:+65-6438-8738 Fax:+65-6438-8793
<http://www.nitta.com.sg>
<Liaison Office> Indonesia, Vietnam

NITTA CORPORATION (THAILAND) LIMITED

7/472 Moo 6, Tambol Mabyangporn, Amphur Pluakdaeng, Rayong Province 21140, THAILAND
Phone:+66-38-018-301 Fax:+66-38-018-304
<http://www.nittathai.com>

NITTA BRASIL

Rua Francisco Mommenshon, 50B, Galpão 02 Laranjeiras, Caieiras, São Paulo, Brazil
Phone/Fax:+55-11-4441-2922
<http://www.nitta.com.br>

CONNECT CONVEYOR BELTING INC.

405 Industrial Drive Unit 3-8, Milton, Ontario Canada L9T 5B1
Phone:+1-905-878-5552 FAX:+1-905-878-0344
<http://www.connectbelting.com>